



AGENDA
City of Lenoir
City Council Meeting
905 West Ave. NW, Lenoir, NC 28645
Tuesday, March 3, 2026 | 6:00 pm



I. CALL TO ORDER

- A. Moment of Silence & Pledge of Allegiance
- B. Lenoir Police Department 2025 Annual Report; Andy Wilson Chief of Police will present the 2025 Annual Report to City Council.

II. MATTERS SCHEDULED FOR PUBLIC HEARINGS

III. CONSENT AGENDA ITEMS

- A. Minutes: Approval of the City Council minutes of the meeting of Tuesday, February 17, 2026, as submitted.
- B. Minutes: Approval of the Committee of the Whole minutes of the meeting of Tuesday, February 24, 2026, as submitted.
- C. Bid Award: Pennell Street Gateway Pedestrian Bridge Repair; Staff recommends awarding the contract to Shotcrete Contractors Inc. for the lump sum of \$59,700.00. Shotcrete Contractors Inc. is the lowest, responsive, responsible bidder, is appropriately licensed and is adequately equipped to perform work of this nature as submitted.

IV. REQUESTS AND PETITIONS OF CITIZENS

V. REPORTS OF BOARDS AND COMMISSIONS

VI. REPORT AND RECOMMENDATIONS OF THE CITY MANAGER

- A. Items of Information
 1. The Planning Board will meet on Monday, March 9 at 5:30 p.m. at the City/County Chambers.
 2. The City/County Services Committee will meet on Monday, March 9 at noon at the J.E. Broyhill Civic Center.
 3. The Economic Development Advisory Committee will meet on Tuesday, March 10 at 8:15 a.m. at the J.E. Broyhill Civic Center.
 4. The ABC Board will meet on Thursday, March 12 at 2:00 p.m.
 5. The Lenoir Business Advisory Board will meet on Thursday, March 12 at 6:00 p.m. at City Hall, Third Floor.
 6. The Leadership Lenoir Civic Learning Academy will meet on Monday, March 9 at 5:30 p.m. at City Hall, Third Floor.
 7. The Parks and Recreation Board will meet on Monday, March 16 at 6:00 p.m. at the Aquatic Fitness Center.

VII. REPORT AND RECOMMENDATIONS OF THE CITY ATTORNEY

VIII. REPORT AND RECOMMENDATIONS OF THE MAYOR

- A. Board Appointment: Mayor Gibbons will recommend to City Council that John Arnaud be appointed to serve on the Planning Board for an unexpired term ending June 2027. This appointment was announced at the February 17, 2026, City Council meeting.

IX. REPORT AND RECOMMENDATIONS OF COUNCIL MEMBER

X. ADJOURNMENT



Lenoir Police Department Council Action Form



I. Agenda Item:

2025 Annual Report to present at the March 3, 2026 City Council meeting.

II. Background Information:

Department stats for the year 2025 for Council Review (follows).

III. Staff Recommendation:

IV. Reviewed by:

City Attorney: _____	Date: _____
City Manager: _____	Date: _____
Police Chief: <u>Charles A. Wilson</u>	Date: <u>2/23/2026</u>



Chief Andy Wilson
Annual Report
2025



LENOIR POLICE DEPARTMENT ANNUAL REPORT

MISSION STATEMENT

It is the mission of the Lenoir Police Department to work in partnership with the community to anticipate, define, and meet the needs of our city in the areas of public safety, community well-being, and law enforcement.

VISION STATEMENT

It is the vision of the Lenoir Police Department to continue our pursuit of excellence by providing the highest quality of police services, enhancing public safety, and improving the quality of life for future generations.

CORE VALUES AND PRINCIPLES

*We, as members of the Lenoir Police Department, believe in the **Core Values** of:*

***Mutual Respect** of the unique qualities of each individual who contributes to the overall well-being of our department and the community we serve;*

***Integrity and Ethical Behavior**, serving all people with honesty, compassion, and respect;*

***Open Partnership** between the police and the community;*

***Public Service** to be responsive, courteous, and effective;*

***Professionalism** by staying current with new trends and standards in the field of law enforcement;*

*We, as members of the Lenoir Police Department, exercise the **Core Principles** of:*

***Courage** to do what is morally and legally solid, despite fear of criticism, retribution, or physical injury;*

***Character** to serve first, then lead, in a fair, honest, and ethical manner;*

***Accountability** in holding ourselves and our colleagues to an unimpeachable standard of professional behavior and service.*



LENOIR POLICE DEPARTMENT ANNUAL REPORT

The Lenoir Police Department plays a vital role in maintaining the safety, stability, and quality of life for the citizens and visitors of the City of Lenoir. This report is intended to provide a comprehensive overview of departmental operations during 2025, and highlight service demand, personnel development, technology investments, and community-focused initiatives across all divisions.

At the core of the department is the Patrol Division, which serves as the backbone of daily operations. Patrol officers provide uninterrupted coverage 24 hours a day, 365 days a year, and are the first responders to every call for service, regardless of severity, weather conditions, or risk. In 2025 alone, patrol officers responded to 39,566 calls for service, both self-initiated and dispatched, underscoring the consistent demand placed on frontline personnel and their critical role in ensuring Lenoir remains a safe place to live, work, and visit.

Supporting Patrol is a coordinated structure of specialized divisions, including Criminal Investigations, Support Services, and Community-Oriented Units, each contributing to public safety through focused expertise. Investigators addressed crimes against persons and property, narcotics-related offenses, nuisance abatement, and complex investigations, while Support Services ensured the department remained operationally sound through communications, training, logistics, records, and evidence management.

Throughout 2025, the department continued to emphasize professional development, accountability, and modernization. Officers and staff achieved advanced state and national certifications, completed thousands of hours of training, and assumed leadership roles through promotions. Strategic investments in technology such as drones, Automated License Plate Readers (ALPR), upgraded communications infrastructure, enhanced firearms optics, and digital evidence storage were made to improve efficiency, accuracy, and safety while remaining mindful of privacy and community trust.

Equally important is the department's ongoing commitment to community engagement. From School Resource Officers, D.A.R.E. instruction, and youth programs like C.A.D.E.T. Camp, to large-scale events such as National Night Out and Project Graduation, officers continue to build positive relationships that extend beyond enforcement and into partnership.

By staying proactive, working together, and continuing to invest in the areas that matter most, we can navigate future obstacles and keep moving forward in a positive direction. With steady progress and a practical approach, as well as the continued support of City Council, city staff, and the citizens we proudly serve, our department will be well-positioned to meet the needs of 2026 and beyond. - Chief Andy Wilson





COMMAND STAFF



Chief of Police

Andy Wilson

828-757-2125

awilson@ci.lenoir.nc.us



Major

Couby Stilwell

828-757-2104

stilwell@ci.lenoir.nc.us



Patrol Division

Captain Martin Crisp

828-757-2144

mcrisp@ci.lenoir.nc.us



Criminal Investigations Division

Captain Mark Barlowe

828-757-2115

mbarlowe@ci.lenoir.nc.us



Support Services Division

Captain Jody Herman

828-757-2148

jherman@ci.lenoir.nc.us



LENOIR POLICE DEPARTMENT ANNUAL REPORT

PATROL DIVISION

The Patrol Division consists of three platoons. A Platoon and B Platoon is comprised of four patrol squads responsible for responding to calls for service and patrolling our community. In 2025, through the restructuring of divisions, C-Platoon was reassigned to the Patrol Division. C Platoon consists of our School Resource Officers, Neighborhood/Community Watch Programs, D.A.R.E, and the Downtown District; they coordinate security for all city events.

Patrol Officers must be able to respond to any call for service no matter the current weather condition or level of danger. One of the many on-going equipment projects completed this year was the procurement of new EOTECH Holographic sights for all department issued rifles for all sworn personnel. These optics are intended to enhance officer accuracy, target identification, and response effectiveness during high risk incidents while maintaining the highest standards of public and officer safety. The department also procured additional drones to assist in locating suspects, missing persons, and runaway juveniles, as well as enhancing security at special events, schools, and athletic events.

Several patrol officers received their Intermediate and Advanced Law Enforcement Certificates through NC Criminal Justice Training and Standards. In order to be awarded such a certificate an officer must acquire a certain amount of training hours as well as credible experience. In most cases officers must possess at minimum of four to eight years of credible service to receive this professional certificate. Corporal Pennell and Officer Pyle received their Intermediate Law Enforcement Certificates. Officer Rubio received his Advanced Law Enforcement Certificate. At year end, 32 officers held either an Advanced (24) or Intermediate (8) Certificate, which is 58% of 55 full-time sworn officers. This percentage earns the City of Lenoir a 7% discount on law enforcement liability insurance.

During the year, Lieutenant Bumgarner graduated from the FBI National Academy. Officer Barrett was nominated by his co-workers for Officer of the Year. Sergeant MacLeod received the American Legion Post 29 Officer of the Year award. Lieutenant Crisp was promoted to Captain and assigned as Patrol Division Commander. Sergeant Moser and Detective Hartley were promoted to Lieutenant and assigned as Patrol Platoon Commanders. Detective Annas and Corporal Zambrano were promoted to Sergeant and assigned as Patrol Supervisors. Officers Pennell, Reid, DiBella and Miller were promoted to Corporal and assigned as Patrol Supervisors. Officer Smith was promoted to Corporal and assigned the duty of Community Resource Liason. Sergeant Foust, Corporal Miller, and Officers Barrett, Brown, Ruppard, and Severt were recognized by city staff for providing exceptional customer service and all received Golden Ticket Awards. Officer Rubio was voted #3 Officer in the Best of Caldwell awards.

Three new K9 Units were added to the Patrol Division in 2025. Handler Reid and canine Cezar and Handler Miller and canine Mia were assigned to patrol shifts. Handler Rubio and canine Genghis were assigned to Hibriten High School. Our department is the first agency in the Western part of North Carolina to implement a K9 full-time at a school.

After the start of the school year, C Platoon welcomed Officer Coulter as the new School Resource Officer (SRO) for Whitnel Elementary, Officer Inman as the new SRO at Valmead Elementary, and Officer Pyle as the new SRO of William Lenoir Middle School.

Officers continue to focus their efforts on reports of debris left by encampments and unsheltered individuals throughout the City of Lenoir. Oftentimes, these abandoned sites are littered with large amounts of trash and debris that needs removal. As a community concern, we make it a priority to revitalize these areas in an effort to limit the number of reoccurring incidents, improve the aesthetics, and reduce the environmental impacts. Our Officers work with businesses, code enforcement, and property owners to assist these individuals with locating resources that benefit the current situations they are facing.





LENOIR POLICE DEPARTMENT ANNUAL REPORT

CRIMINAL INVESTIGATIONS DIVISION

During 2025, the Criminal Investigations Division continued to work diligently with the citizens of Lenoir and within our various communities to investigate criminal acts, as well as deter criminal activities of all types. The Criminal Investigations Division investigated an array of cases in 2025 totaling 743. Crimes against persons and property will continue to be a top priority to assure our citizens have a safe place to live, work and play.

During the year, Lieutenant Blache transferred from the Patrol Division to assume leadership of the Investigations. Officer Ryerse transferred from the Patrol Division into a Detective role. Patrol Corporal Woodward also joined the division as Nuisance Abatement Investigator. Detective Massey was promoted to Detective II. Detective Mooney received the Intermediate Law Enforcement Certificate. Senior Detective Hamrick received the "Top Gun" award for the fourth consecutive year.

Ongoing training remains critical to ensuring investigators maintain the skills and knowledge necessary to effectively serve the citizens of Lenoir. Throughout 2025, division personnel completed a broad range of specialized training courses, including interview and interrogation techniques, the Police Law Institute, forensic classes, crime scene investigations, and narcotics-related instruction.

Supervisors completed advanced leadership training with Lieutenant Blache completing the NC Association of Chiefs of Police Institute, Sergeant January finishing the FBI LEEDA Trilogy, and another Sergeant completing the FBI Command College.

This division continues to work closely with Code Enforcement and the City of Lenoir Planning Department to address nuisance violations throughout our communities. Whenever possible, investigators collaborate with property owners to resolve issues voluntarily. During the year, targeted enforcement efforts led to the investigation of 250 properties for a variety of nuisance violations. Of these cases, 177 were successfully abated either by the property owner or by the City of Lenoir.

The opioid crisis continues to impact families throughout the City of Lenoir and Caldwell County. In 2025, investigators responded to 99 overdose cases, 53 of which were directly linked to opioid use. These incidents continue to disrupt families and strain our community.

Narcotics investigators remain committed to combating the influx of illegal drugs by working in close partnership with local, state, and federal agencies. During 2025, investigators seized \$372,532 in illegal narcotics within the City of Lenoir and assisted other agencies in seizing an additional \$2,680,074 worth of illegal substances. The investigation and prosecution of individuals who illegally distribute these deadly narcotics remain a top priority.

In response to direct community complaints regarding ongoing safety and nuisance concerns at the Red Roof Inn property, our investigators collaborated with the North Carolina Alcohol Law Enforcement Division that resulted in a signed Consent Judgement filed at the Caldwell County Clerk's office and Register of Deeds. With this process, we are happy to report that the property has been better managed and issues associated with it have significantly subsided.

The Flock Automated License Plate Reader (ALPR) system is a network of fixed, high-resolution cameras paired with cloud-based software that captures license plate numbers and vehicle attributes, such as make, model, color, and other identifying characteristics, when vehicles pass through designated locations. The system allows law enforcement to search vehicle data, receive real-time alerts for stolen vehicles or vehicles of interest, and more efficiently develop investigative leads, focusing on vehicle information.

This year, our agency installed the Flock ALPR system at 15 strategic locations throughout the city to enhance crime prevention efforts, improve response times, and strengthen investigations into vehicle-related crimes, missing persons, and other public safety concerns. The system is integrated with the National Crime Information Center (NCIC) database, allowing officers to receive immediate alerts when a license plate associated with a stolen vehicle, wanted person, missing person or other NCIC entry is detected, further increasing the effectiveness of the department's proactive policing efforts while operating under established privacy protections and data retention policies.

Through the continued support of the City Council, city staff, and citizens, investigators have been able to acquire advanced audio and video technology to more effectively investigate crimes that have already occurred, as well as criminal activity in general. As technology advances in society, so do the methods used by those who commit crimes. To thoroughly investigate incidents, it is essential that we remain current with equipment needs, provide ongoing training opportunities, and maintain strong partnerships with local, state, and federal agencies. Utilizing all of these resources will enhance investigative success and help ensure the safety and peace of mind our citizens deserve.



LENOIR POLICE DEPARTMENT ANNUAL REPORT

SUPPORT SERVICES DIVISION

The Support Services Division manages and oversees various administrative functions for the police department. These functions include training, logistics, records, evidence, and the communications center.

During the year, Communications received 52,813 total phone calls. Of those calls, 7,220 were processed as 911 emergency calls and 10,292 were non-911 calls for service. The communications center processed 21,642 officer-initiated calls and made 39,566 CAD entries. In addition, communication's personnel processed and received 315 after-hours water and sewer service calls for the City of Lenoir.

Our communications personnel continue to advance their level of knowledge through various training and certification opportunities. T/Os Hollar, Davis, Andrews, Brown, Taylor and Stamey were all certified through the NC Sheriff's Standards Commission. MTO Hollingsworth became the new Director of Communications and was voted #1 Best of Caldwell Dispatcher for 2025. His predecessor Eller transitioned into the role of Evidence Technician. MTO Hollowell was awarded Civilian Employee of the Year, as nominated by her coworkers, and Golden Ticket Awards were given to T/O Walker, T/O Dula, and T/O Ford for providing outstanding customer service.

Upgrades include the the procurement and installation of Kenwood VM5930 mobile radios that were imperative to ensure compliance with P25 Phase 2 Viper Radio requirements by the recognized deadline of July 1, 2025. The purchase and install of (43) mobile in-car radios at a cost of \$147,000 accomplished this goal and assured continued communication and compliance. Due to the upgraded in-car radios for compliance with Phase 2 of Viper Radio requirements, our current radio infrastructure within the in-house communications capabilities had to be upgraded at a cost of \$3,400.

The training section of the department is responsible for all hiring processes, promotional processes, overseeing annual in-service requirement, and maintaining records on all training and certifications. During 2025, there were 35 background investigations and 28 hiring processes. In addition, there were 10 promotional processes (1 Evidence, 2 SRO, 1 K-9, 1 Communications Director, 2 Detective, 2 Corporal, and 1 Lieutenant). The Training Coordinator was tasked with preparing and submitting the agency's training compliance reports to the state, as well as improving the department's Field Trainine Evaluation Program and digitizing numerous documents.

Over the year, 2,327 pieces of incoming evidence was processed; 2,119 pieces of evidence were disposed of per Court Order. 144.6 pounds of unused or unwanted medication was collected through a community event and lobby drop box and disposed of properly. A new evidence storage hard drive was added to assist with digital media storage, which is increasingly more prevalent. The department continues to focus on an overall evidence audit to ensure accountability and overall best evidence practices.

Logistics oversees inventory, purchasing, and Internal Affairs for the department. During the year, 3 new vehicles were procured and assigned to the Patrol Division. We also switched to Lenovo in-car computers for Patrol vehicles to keep pace with the ever-changing, ever-increasing digital security and capabilities. Desk top computers will be replaced with Lenovo laptops and docking stations. Our entry gate keypads were upgraded to allow the use of entry door cards and cell phones to activate the gates and increase facility security. We were also fortunate to receive a surplus trailer from the City's Parks & Recreation Department, which can be deployed to incident scenes or special events and efficiently transport cones to assist with traffic control and area closures.

As in prior years, officers demonstrated their commitment to maintaining the safety of the City of Lenoir's highways and streets, ensuring a secure environment for both residents and visitors through participation in the Governor's Highway Safety Program. Campaigns such as "Speed a Little - Lose a lot", "Move Over or Get Pulled Over", "Click it or Ticket", "Booze it or Lose it", and the Child Passenger Safety initiatives has granted our agency the ability to purchase traffic cones, a Bosch Crash Data Recorder with one-year subscription, as well as Alco sensors, at a savings of \$8,750.

In September, a more deliberate Facebook Social Media strategy was implemented to increase consistent posting, professional branding, and purposeful messaging. This enhanced focus has strengthened communication with the community by providing timely updates, educational content, and insight into departmental operations. We feel that a consistent and professional online presence will support our recruitment efforts by highlighting the department's culture, values, and commitment to service, while reinforcing public trust and engagement.



LENOIR POLICE DEPARTMENT ANNUAL REPORT

	Instructor Training Hours	394
Armorers Re-Certification		72
General Instructor Update (14) & Certification (276)		290
Less Lethal Instructor		32
	Investigative Training Hours	351
Basic Narcotics Investigator School		24
Crime Scene Processing		7
General Criminal Investigations		40
FBI Regional Crisis Negotiation Course		80
Forensic Analysis of Bloodstain Patterns		40
Fundamentals of CSI		24
Narco Culture Course Level IV		40
NC Narcotics Association Conference		56
Preventing / Countering Violent Extremeism		24
Suicide Investigation		16
	School Resource Training Hours	180
Active Shooter Training		72
NCA SRO Annual Training Conference		64
Sexual Harassment Prevention		1
SRO Crime Prevention Through Environment		1
SRO Training		40
SRO Update		2
	Special Response Team Training Hours	1304
Basic SWAT		400
SRT Non-Specified		904
	State Mandated Training Hours	4212
Bloodborne Pathogens & Hazmat		344
Communication Barriers		16
DCI Criminal Record Inquiries, File Transactions, General Inquiries & Modules 1, 2, 3		38
Ethics: Leading by Example (136); Protecting Confidentiality (2)		138
Evidence Handling Best Practices		88
Field Training Evaluation Program		2196
Firearms Classroom, Combat & Qualification		684
Handling Crisis & Critical Situations		24
Juvenile Justice		118
Mental Health / Cultivating Resiliency		112
Legal Update (208) & Legislative Update (102)		310
Maintaining Control of the Communications Center		12
Recognizing & Responding to Hazardous Substances		74
Resolving Conflict Through Communications		20
Security Awareness Training		38
	Supplemental Training Hours	3405
At-Scene Traffic Crash Investigation		80
Basic K-9 / Narcotics Course		380



LENOIR POLICE DEPARTMENT ANNUAL REPORT

Basic Rifle Course	48
Cellebrite Certified Operator & Physical Analyst; Gathering Evidence From Today's Communication Devices	43
Child Passenger Safety Tech Training	16
CJLeads	4
Compliance & Control Techniques	111
Crisis Intervention Technician	120
CPR Certification & Re-Certification	30
Driver's Training	324
Drones for First Responders (64); UAS - Remote Pilot License Re-Certification (6)	70
e-Warrants	24
Evidence & Property Mgmt; Basic Evidence Mgmt; Evidence Mgmt for Supervisors	56
Field Training Officer Training	320
Fire Extinguisher Training	65
Flock Safety Training: Administrator, Alert Tools, Searches	43
Huntress I.T. Training: Elevated Privileges, Passwords, Phishing	8
Interview & Interrogation	200
Intox EC/IR Operator School	120
Intoximeter Re-Certification	8
Motorcycle Crash Investigation	64
NCLM Driver Training	16
New Hire: Conduct, Firearms, Garrity, I.T., Naloxone, Pursuit, OC, SCAT, Taser, UOF, Verbal Conflict, Weapons Maint.	232
NHTSA STEST (24 Hour)	108
Notary Certification	6
Outlaw Motorcycle Club Gang Training	15
Pedestrian Crash Reconstruction	64
Shoot / Don't Shoot Scenario Drills	351
Speed Measuring Instrument Operator & Re-Certification	176
Traffic Crash Reconstruction	80
Telecommunicator Certification	47
Understanding & Responding to Civil Processes	176
Supervisory Training Hours	
	606
Background Investigations	48
Budget for Police Managers	52
Chief Leadership Institute	80
CIT Coordinator Certification Course	8
Command Institute for Executives	56
FBI-LEEDA Executive Leadership Institute	28
FBI-LEEDA Supervisor Leadership Institute	56
First Line Supervision	40
In-Service Training Coordinator	8
Managing Police Records	14
NC FBI Command College	48
Police Law Institute	152
Use of Force Review for Supervisors	16
TOTAL TRAINING HOURS	
	10452



Lenoir Police Department Organizational Structure

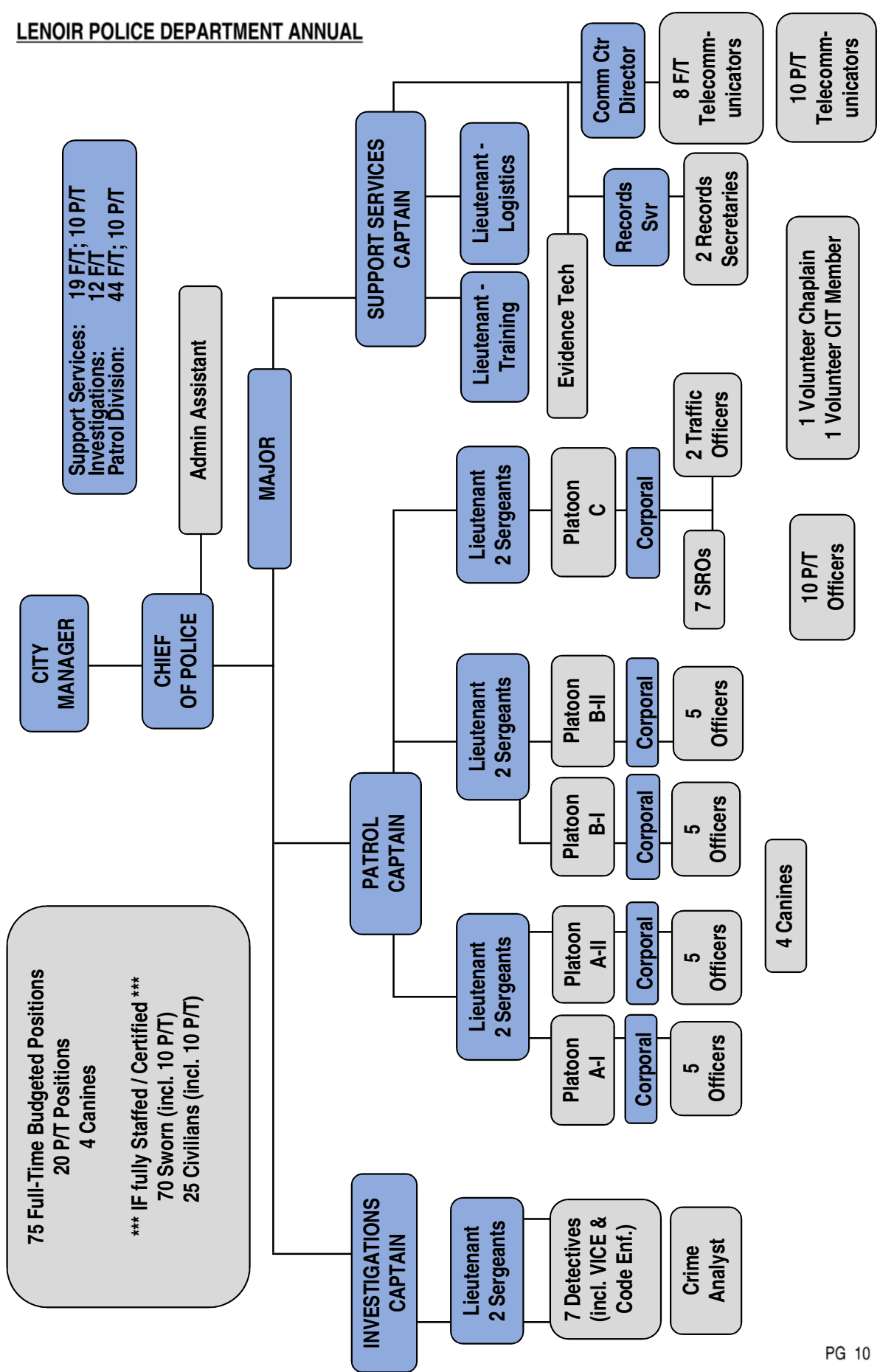



LENOIR POLICE DEPARTMENT ANNUAL REPORT

ENFORCEMENT ACTIVITY BY RACE

2025

	Arrests				Traffic Stops		Use of Force	
	Felony		Misdemeanor					
Black	83	21.7%	364	23.2%	532	13.9%	5	23.8%
Other	4	1.0%	10	0.6%	123	3.2%	0	0.0%
White	295	77.2%	1193	76.1%	3184	82.9%	16	76.2%
TOTALS	382	100%	1567	100%	3839	100%	21	100%

Felony Arrests

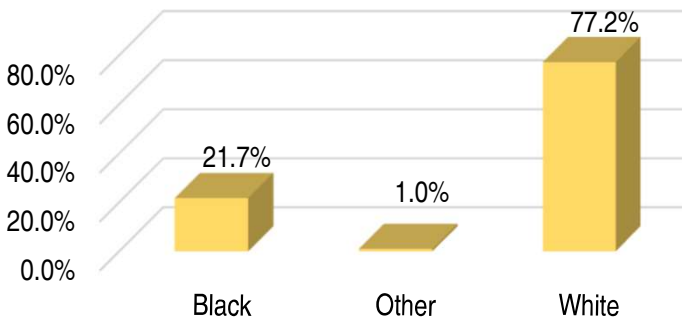

Misdemeanor Arrests

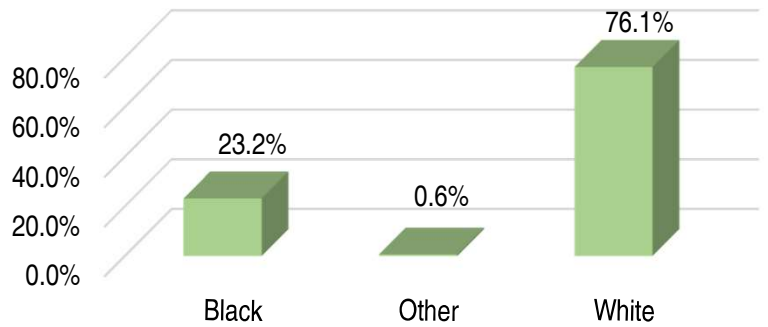

Traffic Stops

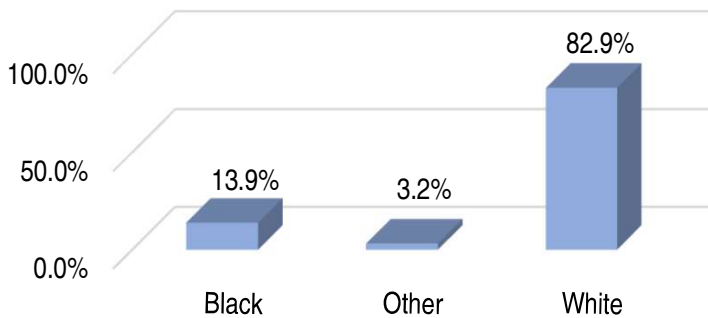

Use of Force

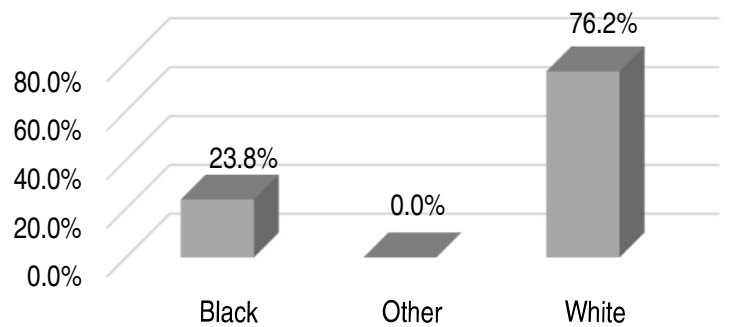



LENOIR POLICE DEPARTMENT ANNUAL REPORT

CRIMES AGAINST PERSONS

Code	Charge Description	2022	2023	2024	2025
13A	Aggravated Assault	19	27	24	33
11D	Forcible Fondling	13	18	25	16
11A	Forcible Rape	20	7	10	15
11B	Forcible Sodomy	3	2	2	7
64A	Human Trafficking (Commercial Sex Acts)	0	0	0	0
64B	Human Trafficking (Involuntary Servitude)	0	0	0	0
36A	Incest	0	1	2	1
13C	Intimidation	11	12	36	42
09C	Justifiable Homicide	0	1	0	0
100	Kidnapping / Abduction	3	2	1	3
09A	Murder / Non-Negligent Manslaughter	0	0	0	1
09B	Negligent Manslaughter	0	0	0	0
11C	Sexual Assault with Object	2	4	3	0
13B	Simple Assault	324	298	283	325
36B	Statutory Rape	0	1	2	8
TOTALS		395	373	388	451

CRIMES AGAINST SOCIETY

Code	Charge Description	2022	2023	2024	2025
720	Animal Cruelty	4	5	6	1
40B	Assisting / Promoting Prostitution	0	0	0	1
35A	Drug / Narcotic Violations	290	263	276	247
35B	Drug Equipment Violations	102	103	112	120
39A	Gambling (Betting / Wagering)	0	0	0	0
39C	Gambling (Equipment Violations)	0	0	0	0
39B	Gambling (Operating / Promotion)	0	0	0	0
39D	Gambling (Sports Tampering)	0	0	0	0
370	Pornography / Obscene Materials	4	6	10	5
40A	Prostitution	0	0	0	0
40C	Purchasing Prostitution	0	0	0	0
520	Weapons Law Violations	38	34	43	36
TOTALS		438	411	447	410



LENOIR POLICE DEPARTMENT ANNUAL REPORT

CRIMES AGAINST PROPERTY

Code	Charge Description	2022	2023	2024	2025
200	Arson	1	3	8	6
510	Bribery	0	0	0	0
220	Burglary / Breaking & Entering	174	112	171	144
250	Counterfeiting / Forgery	10	6	14	6
290	Destruction/ Damage/ Vandalism of	198	135	167	172
270	Embezzlement	1	1	2	3
210	Extortion / Blackmail	1	0	0	3
26G	Hacking / Computer Invasion	0	1	0	0
26F	Identity Theft	5	2	4	3
23H	Larceny (All Other)	204	203	208	211
23D	Larceny (From Building)	37	35	39	43
23E	Larceny (From Coin-Operated Machines / Devices)	2	1	2	1
23F	Larceny (From Motor Vehicles)	83	69	63	54
23G	Larceny (Motor Vehicle Parts and Accessories)	18	9	10	24
23A	Larceny (Pick-Pocket)	0	0	0	1
23B	Larceny (Purse Snatching)	1	0	0	0
23C	Larceny (Shoplifting)	116	92	87	67
240	Motor Vehicle Theft	79	60	48	41
26B	Fraud (Credit / Debit Card / ATM)	48	42	36	27
26A	Fraud (False Pretense / Swindle / Confidence Game)	62	35	57	57
26C	Fraud (Impersonation)	9	8	14	17
26D	Fraud (Welfare)	0	0	0	0
120	Robbery	6	1	11	9
280	Stolen Property	4	17	10	8
26E	Wire Fraud	0	2	0	0

TOTALS	1059	834	951	897
--------	------	-----	-----	-----

CRIME STOPPERS

Description	2022	2023	2024	2025
Calls Received	231	125	127	160
Illegal Narcotics Recovered	\$0	\$0	\$1,270	\$0
Rewards Paid	\$2,550	\$0	\$950	\$2,200
Stolen Property Recovered	\$3,000	\$90	\$300	\$6,000
Total Arrests	3	2	8	5



LENOIR POLICE DEPARTMENT ANNUAL REPORT

GROUP B OFFENSES

Code	Charge Description	2022	2023	2024	2025
90A	Bad Checks	0	2	1	0
90B	Curfew / Loitering / Vagrancy	0	0	0	0
90C	Disorderly Conduct	20	15	14	14
90D	Driving under Influence	32	27	36	52
90E	Drunkenness	1	1	6	14
90F	Family Non Violent Offenses	216	117	175	171
90G	Liquor Law Violations	3	2	0	2
90H	Peeping Tom	1	0	1	2
90I	Runaways	13	31	22	8
90J	Trespass of Real Property	1	1	17	12
90Z	All Other Offenses (Person / Property / Society)	4	10	11	8
TOTALS		291	206	283	283

CALLS FOR SERVICE

Description	2022	2023	2024	2025	
Alarms	1500	1446	1417	1288	
Animal Complaints	311	293	328	261	
Civil Disturbances	940	893	862	767	
Domestic Disturbances	1071	847	865	915	
Field Contacts	303	251	584	853	
Follow-Ups	1113	960	986	933	
Foot Patrols	200	175	100	125	
Incomplete 911s	2265	2958	2315	2280	
Loud Noise Complaints	208	230	249	205	
Special/House Checks	9914	11307	12256	11813	
Stranded Motorists	575	511	551	446	
Suspicious Persons	2275	2308	2479	2620	
Suspicious Vehicles	1396	1086	1108	1020	
Warrant Service	1034	911	732	648	
TOTALS		23105	24176	24832	24174

Group B offenses are non-reportable and consist of Crimes Against Society, except bad checks, runaway juvenile, and all other offenses.
Runaway juvenile is not classified as a crime by the FBI, but we feel documentation is warranted.



LENOIR POLICE DEPARTMENT ANNUAL REPORT

CANINE ACTIVITIES

Description	2022	2023	2024	2025
Building Searches	26	5	7	35
Building Search Apprehensions	6	1	1	6
Call Outs	0	0	0	0
Demonstrations	0	2	1	12
Currency Seized	\$518	\$0	\$11,100	\$1,398
Assist Narcotics Searches	16	12	23	70
Assist Narcotics Seizures	2	4	15	64
Narcotic Utilizations	151	140	68	178
Street Value of Seized Narcotics	\$21,649	\$27,592	\$42,375	\$83,213
Tracks	23	4	2	6
Tracks Apprehensions	3	1	0	3
Training Hours	158	248	121	557
Utilizations	186	77	65	241

CHARGES / ARRESTS

Description

Felony Charges	2022	2023	2024	2025
Adult	616	605	625	532
Juvenile	1	6	17	4

Misdemeanor Charges

Adult	2276	2271	1960	1984
Juvenile	29	32	55	57

TOTALS	2922	2914	2657	2577
--------	------	------	------	------

<i>Figures to the right are arrests stemming from charges above. Involuntary Commitments are included in misdemeanor arrest totals.</i>	Felony Arrests	409	412	447	384
	Misdemeanor Arrests	1859	1864	1743	1574
	Involuntary Commitments	210	222	227	268



LENOIR POLICE DEPARTMENT ANNUAL REPORT

TRAFFIC

Description	2022	2023	2024	2025
Crashes				
Crashes with Injuries	167	210	214	203
Crashes with Property Dmg	885	1031	818	818

TOTALS	1052	1241	1032	1021
--------	------	------	------	------

Figures to the right are included in the totals above.	Fatalities	5	3	5	3
	Hit & Runs	205	226	212	228
	Parking Lots	265	325	262	286

For the year 2025, we had 6 pedestrians injured in traffic crashes.

Tickets	2022	2023	2024	2025
Handicap Tickets Issued	3	3	3	0
Parking Tickets Issued	157	240	221	49
Parking Tickets Paid	157	184	223	48
Traffic Citations Issued	2460	2102	2027	2438
Warning Tickets Issued	1186	1194	1258	1214

Top Five Contributing Circumstances 2025

Failure to Reduce Speed	170
Failure to Yield Right of Way	149
Improper Backing	126
Inattention	121
Improper Turn	80

Top Five Crash Locations 2025

Blowing Rock Blvd / Hospital Ave	20
Blowing Rock Blvd / Seehorn St	16
Blowing Rock Blvd / McLean Dr	15
Blowing Rock Blvd / ABC Ct	11
Hickory Blvd / Greenhaven Dr	11



LENOIR POLICE DEPARTMENT ANNUAL REPORT

ADMINISTRATIVE

Description	2022	2023	2024	2025
ABC Permits	11	12	15	16
Backgrounds	24	30	33	35

COMMUNICATIONS

Description	2022	2023	2024	2025
CAD Requests DSS	269	199	118	79
Criminal History Requests	275	279	241	255
Entered CAD Calls	38592	40329	40689	39566
Interpreter Requests (all Spanish)	21	15	11	29
Number of Monthly Validations	817	814	796	790
Utility Calls	458	333	224	240

RECORDS

Description	2022	2023	2024	2025
CAD Reports	\$160	\$315	\$265	\$325
Fingerprints	\$70	\$120	\$105	\$75
Parking Ticket Payments	\$625	\$1,245	\$2,020	\$425
Reports	\$205	\$125	\$55	\$90

TOTALS	\$1,060	\$1,805	\$2,445	\$915
---------------	----------------	----------------	----------------	--------------

PROPERTY & EVIDENCE

Description	2022	2023	2024	2025
Evidence Disposed	4324	1399	1156	2119
Evidence Received	2323	2349	2160	2327
Evidence Items to Date	49408	51542	53702	56029

In 2025, 144.6 lbs. of unused/unwanted medication was collected from the lobby drop box and one community event.



LENOIR POLICE DEPARTMENT ANNUAL REPORT

GENERAL INVESTIGATIONS

Description	2022	2023	2024	2025
Interviews / Forensic Interviews	494 / 35	377 / 13	669 / 28	682 / 37
Recovered Stolen Property	\$718,596	\$327,452	\$94,002	\$160,047
Recovered Stolen Vehicles (number of)	67	58	31	32
Recovered Stolen Vehicles (value of)	\$481,000	\$466,754	\$175,351	\$149,544
Narcan Use	73	69	68	64
Overdoses	161	140	111	99
<i>Opioid Induced Overdoses</i>	<i>99</i>	<i>93</i>	<i>69</i>	<i>53</i>
Suicides	10	9	5	8
Unattended Deaths	58	43	51	45

Narcan is used to reverse fatal drug overdoses. In 2025, we likely saved 50 lives with Narcan administration.

CASE STATUSES

Description	2022	2023	2024	2025
Open	469	349	392	418
Inactive	1163	1061	784	764
CBA (Cleared by Arrest)	400	335	227	1017
Exceptionally Cleared	34	33	17	23
Unfounded	119	117	133	143
TOTALS	2185	1895	1553	2365

NUISANCE

Description	2022	2023	2024	2025
Offenses				
Abandoned / Junk Vehicle	15	10	17	13
Graffiti	0	45	11	7
Health and Safety	13	19	18	29
Junk and Debris	74	68	88	104
Miscellaneous	4	4	10	9
Tall Grass or Vegetation	72	61	71	88
TOTALS	178	207	215	250
Case Statuses				
City Abated	27	30	33	27
Owner Abated	103	97	111	150



LENOIR POLICE DEPARTMENT ANNUAL REPORT

NARCOTICS ACTIVITIES

Description	2022	2023	2024	2025
Arrests / Charges	54 / 124	20 / 38	31 / 67	30 / 67
Arrests While Assisting Other Agencies	0	0	0	0
Charges While Assisting Other Agencies	0	0	0	0
Cases Opened or Initiated Within City Limits	189	104	113	53
Cases Opened or Initiated While Assisting Other Agencies	33	43	76	81
Cash and Property Seized	\$859,674	\$786,555	\$94,271	\$37,695
Cash and Property Seized While Assisting Other Agencies	\$205,506	\$4,201	\$386,541	\$32,166
Illegal Narcotics Seized	\$1,314,701	\$4,041,427	\$630,381	\$372,532
Illegal Narcotics Seized While Assisting Other Agencies	\$2,524,317	\$568,651	\$3,519,210	\$2,680,074
Knock and Talks	15	10	16	17
Search Warrants	94	72	62	29
Total Assists and Joint Investigations	33	43	76	81
Vehicle Seizures	2	0	0	0

NARCOTICS CONFISCATED

Description	2025
Drug Name	Quantity Value
Alprazolam	51 du \$610
Buprenorphine	9 du \$225
Carisoprodol	1 du \$10
Clonazepam	68 du \$848
Cocaine	464.8 g \$34,330
Crack Cocaine	218 g \$43,600
Fentanyl	212.7 g \$127,620
Heroin	
Hydrocodone	
Lorazepam	2 du \$10
Marijuana	4837.9 g \$38,716
Marijuana Plants	2 \$5,000
Methamphetamine	748.7 g \$112,300
Mushrooms	236.5 g \$3,548
Oxycodone	289 du \$3,855
Percocet	4 du \$100
Suboxone	2 du \$20
THC Liquid	87 du \$1,740
Tramedol	
Unknown Drug	
TOTAL	\$372,532



LENOIR POLICE DEPARTMENT ANNUAL REPORT

ALCOHOLIC VIOLATIONS

Description	2022	2023	2024	2025
Aiding & Abetting Minor (Possess/Purchase of Alcohol)	0	0	1	1
Allowing Consumption of Malt Beverage w/o a Permit	0	0	1	0
Consuming at an Off-Premise Establishment	1	0	1	2
Consuming in a City Park	0	0	1	0
Consuming on a Public Road				1
Consuming Under of 21				3
Contributing to the Delinquency of a Minor	0	7	15	4
Defrauding a Drug / Alcohol Screening Test	0	0	1	0
Driving Under the Influence	0	0	0	0
Driving While Subject to Impairing Substance	25	26	26	43
Disorderly Conduct	0	0	0	0
Driving While Impaired	2	4	9	7
Driving While License Revoked Impaired Revocation	0	0	0	0
Drunkenness	0	0	0	0
Hold Until Sober	7	19	25	14
Impaired Driving Revocation	4	0	3	0
Intoxicated and Disruptive	3	13	12	18
Open Container in a Vehicle	3	0	1	2
Public Consumption	1	0	0	0
Sell/Give Malt Beverage and/or Unfortified Wine to < 21	0	1	0	0
Tranporting an Open Container After Consuming	0	0	1	1
TOTALS	46	70	97	96

DRUG CHARGES

Description	2022	2023	2024	2025
Felony Drug Charges	115	150	207	177
Misdemeanor Drug Charges	157	145	157	113
TOTALS	272	295	364	290





LENOIR POLICE DEPARTMENT ANNUAL REPORT

SCHOOL RESOURCE AND COMMUNITY ENGAGEMENT

Our School Resource Officers (SROs) conducted over 35 lockdown drills across our city schools and assisted with more than 20 fire drills. Site surveys and threat assessments were conducted at all schools, ensuring that they were thoroughly assessed for safety and security. Officers provided security for over 50 sporting events and ensured safety at Hibriten High School's graduation and Project Graduation at Bo's Entertainment.

In February, Hibriten High School's SRO, Cesar Rubio, became a K-9 officer and now he and Genghis, an English Springer Spaniel, work together as a team both in and out of the school. Lenoir Police Department is the 1st agency in the Western part of North Carolina to implement a K-9 full-time at a school.

LT Bumgarner and CPL Lynn attended Morganton Public Safety's National Night Out. SRO's from Davenport Elementary and Valmead Elementary taught DARE to 5th grade classes at their respective schools. Kids who participated learned a lot about personal responsibility and making good decisions.

MPO Ruppard continues to serve with Safe Kids and participated in monthly Child Seat Diversion stations. C Platoon officers also provided security for numerous downtown events, ensuring safety for all attendees.

Horizons Elementary SRO Jason Ramsey, participated in a fundraiser to purchase school supplies. His "winning" the competition resulted in him kissing a donkey – anything for a good cause!

C Platoon conducted a coordinated school supply drive to support local students. Officers visited Walmart to purchase backpacks and essential school supplies, including notebooks, paper, pencils, markers, crayons, erasers, and other necessary items. The filled backpacks were distributed to Lenoir's elementary schools and provided to students who might otherwise lack these essential resources

This year's CADET Camp provided an action-packed weeklong camp for local youths who want to get up close and personal with first responders while also going on field trips and having a blast with their peers. This year's lineup included indoor rock climbing, the Hickory Aviation Museum, swimming, fishing, and a Hickory Crawdads baseball game with fireworks to end the night!



Our 2nd Annual CADET Camp was a great success, growing from 20 to 30 students.

Collection of photos from the Year - Lenoir Police Department Annual Report 2025



Officers on hand for Kindergarten Tours



MPO Ruppard at the Bike Safety Event



Giving out candy during Downtown Halloween event



K9 Officers teaching at Citizens Canine Academy



Participation during National Litter Sweep



SRO Rubio & K9 Genghis in the classroom

**LENOIR CITY COUNCIL
MEETING MINUTES
TUESDAY, February 17, 2026
6:00 P.M.**

PRESENT: Mayor Joe Gibbons presiding. Mayor Pro-Tem Ike Perkins, Councilmembers present were Jonathan Beal, Rebecca Dellinger, Ralph Prestwood, Kimmie Rogers, David Stevens, City Manager Scott Hildebran, City Clerk Lauren Hartley and Attorney Timothy Rohr.

CITY STAFF: In attendance was Finance Director Donna Bean, Public Services Public Works Director Jon Hogan, Communication & Public Information Director Joshua Harris, Fire Chief Norman Staines, Police Chief Andy Wilson, Planning Director Hannah Williams, City Parks & Recreation Director Phil Harper, Public Services Public Utilities Director Jeff Church, and Economic Development Main Street Director Brenda Floyd.

ABSENT: Councilmember Crissy Thomas

I. CALL TO ORDER

Mayor Gibbons asked for everyone to keep their thoughts and prayers for the family of Mary Poteat, who passed away and was a longtime volunteer for the City, and for the family of former employee Kaylynn Horn upon the death of her father who passed away in Florida.

- A. The meeting was opened by a moment of silence and the pledge of allegiance as led by Mayor Gibbons.
- B. Special Recognition: On behalf of City Council, Mayor Gibbons read and presented a proclamation to Communication & Public Information Director Joshua Harris proclaiming February 20, 2026, as Government Communicators Day.

Mayor Gibbons said Joshua Harris does a great job and the City appreciates him keeping everyone informed.

Joshua Harris thanked the Mayor and council for the recognition and said he has worked in local government for more than 18 years. Harris also thanked department directors, staff and council for being responsive in getting information out to the public.

II. MATTERS SCHEDULED FOR PUBLIC HEARING:

- A. A public hearing was held concerning the city's intent to apply for a Community Development Block Grant (CDBG) and receive citizen input in the development of Community Development Block Grant Disaster Recovery (CDBG-DR) applications for the coming year. CDBG funds may be used for Disaster Recovery (DR) activities including support to help communities deal with recovery from Hurricane Helene including housing. All projects must predominately benefit low-and moderate-income persons.

Western Piedmont Council of Governments (WPCOG) Community and Economic Development Manager Kyle Case said this public hearing is to discuss an upcoming opportunity for funding through the Community Development Block Grant Disaster Recovery program. This public hearing is to announce the City's intent to apply for this funding within the next 12 months. Kyle Case said WPCOG does anticipate opportunities for infrastructure projects, housing, and commercial district revitalization projects. Once more guidelines are released, a second public hearing will be held.

Mayor Gibbons asked if anyone would like to address the council concerning this public hearing. With none, Mayor Gibbons closed the public hearing.

III. CONSENT AGENDA ITEMS:

Mayor Gibbons presented the following items:

- A. Minutes: Approval of the City Council minutes of the meeting of Tuesday, February 3, 2026, as submitted.
- B. Minutes: Approval of the City Council Planning Retreat minutes of the meeting of Friday, February 6, 2026, as submitted.
- C. FY2026 Audit Contract; Approval of the FY2026 Annual Audit Contract for the City of Lenoir as submitted by C. Randolph CPA, PLLC for audit services in the amount of \$45,000.
- D. Surplus Resolution: Pursuant to N.C.G.S. §20-187.2, Staff recommends City Council adopt a resolution to declare the following police weapon (Sig Sauer P-320 Pistol, Serial Number 58J472282) and police badge of Sergeant Matt Spears upon retirement, as surplus and no longer have any additional use to the City of Lenoir as submitted.
- E. Proclamation; Government Communicators Day: Approval of a proclamation proclaiming February 20, 2026, as "Government Communicators Day" as submitted.
- F. Resolution; Staff recommends approval of a resolution to declare the City of Lenoir's support regarding implementation of a compliant National Pollutant Discharge Elimination System (NPDES) Municipal Separate Storm Sewer System (MS4) to discharge stormwater, inclusive of the required Stormwater Management Plan prepared by the City of Lenoir and the Western Piedmont Council of Governments (WPCOG) and approved by the North Carolina Department of Environmental Quality (NCDEQ) as submitted.

Upon a motion by Mayor Pro-Tem Perkins, City Council voted 6 to 0 to adopt the above listed items (A through F) on the Consent Agenda as listed and recommended.

IV. REQUESTS AND PETITIONS OF CITIZENS

Mayor Gibbons read a statement from City Council concerning the sleeping pods that are located in Downtown Lenoir with His Humble Hands.

The Mayor then asked if there were any request and petitions of citizens.

The following people spoke in support of His Humble Hands.

- Joseph Twist of 107 Forest Hill Drive
- Mark Alan-no address
- Beth Whisnant of 2134 Harper Ave
- CEO of His Humble Hands Denise Ariztia of 532 Harper Ave
- David McGuinn of 317 Pennell Street NE

- Susanna Miller-no address
- Manager, Thrift Store with His Humble Hands Lynn Elliott of 532 Harper Ave
- Cory Howard-no address
- Tabatha Barrier-no address

Other speakers include:

- Western Piedmont Council of Governments (WPCOG) Homeless Response Manager Amber Brafford spoke about services and assistance the WPCOG provides to the homeless.
- City of Lenoir Fire Marshall Chris Jacobs spoke about the rules and procedures for warming stations in the City.

Mayor Gibbons thanked everyone for their comments and said the City does have to follow State laws and city staff is doing a great job.

V. REPORTS OF BOARDS AND COMMISSIONS

VI. REPORT AND RECOMMENDATIONS OF THE CITY MANAGER

City Manager Scott Hildebran presented the following items of information:

1. The Committee of the Whole will meet on Tuesday, February 24 at 8:30 a.m. at City Hall, Third Floor.
2. The Foothills Regional Airport Authority will meet on Wednesday, February 25 at noon.

VII. REPORT AND RECOMMENDATIONS OF THE CITY ATTORNEY

There was no report from the City Attorney.

VIII. REPORT AND RECOMMENDATIONS OF THE MAYOR

- A. Mayor Gibbons recommended John Arnaud to serve on the Planning Board for an unexpired term ending June 2027 and for council consideration at the March 3 council meeting.

IX. REPORT AND RECOMMENDATIONS OF COUNCILMEMBERS

X. ADJOURNMENT

There being no further business, Mayor Gibbons adjourned the meeting at 6:57 p.m.

Lauren Hartley, City Clerk

Joseph L. Gibbons, Mayor



CITY MANAGER
SCOTT E. HILDEBRAN

CITY OF LENOIR
NORTH CAROLINA

MAYOR
JOSEPH L. GIBBONS

CITY COUNCIL
J. T. BEAL
R.C. DELLINGER
J. I. PERKINS
R. S. PRESTWOOD
K. R. ROGERS
D. F. STEVENS
C. D. THOMAS

**PROCLAMATION
GOVERNMENT COMMUNICATORS DAY
FEBRUARY 20, 2026**

WHEREAS, the role of government communications professions is to inform, educate and engage their communities; and

WHEREAS, robust communication in government creates trust and inspires residents to take action and be involved; and

WHEREAS, government communications create relationships and calls to action, build awareness and understanding through storytelling, engage and foster engagement on civic issues, and use all channels to include people in critical decisions; and

WHEREAS, it is essential to have strong communications in government because it is a foundational element of living in a democracy where citizens have the freedom to make their voice heard; and

WHEREAS, the City of Lenoir is proud and has deep gratitude and recognition for government communicators' professionalism, dedication, hard work, commitment, enthusiasm and sacrifice;

NOW, THEREFORE, I, Mayor Joseph L. Gibbons do hereby proclaim February 20, 2026, as

GOVERNMENT COMMUNICATORS DAY

in the City of Lenoir and encourage all residents to thank the members of the Communications & Public Information Department who have dedicated their careers to ensure Lenoir has effective, impactful and successful communication strategies that resonate and are relevant.
This the 20th day of February 2026.

SEAL



Joseph L. Gibbons, Mayor



C. Randolph CPA, PLLC
Certified Public Accountant
560 Beaver Creek School Rd.
West Jefferson, North Carolina 28694
Phone: (336) 846-3211
Fax: (336) 846-1142

To the Honorable Mayor, City Council and Finance Director

City of Lenoir

PO Box 958

Lenoir, NC 28645

We are pleased to confirm our understanding of the services we are to provide for City of Lenoir for the year ended June 30, 2026.

Audit Scope and Objectives

We will audit the financial statements of the governmental activities, the business-type activities, the aggregate discretely presented component units, each major fund, and the aggregate remaining fund information, including the disclosures, which collectively comprise the basic financial statements, of City of Lenoir as of and for the year ended June 30, 2026. Accounting standards generally accepted in the United States of America (GAAP) provide for certain required supplementary information (RSI), such as management's discussion and analysis (MD&A), to supplement City of Lenoir's basic financial statements. Such information, although not a part of the basic financial statements, is required by the Governmental Accounting Standards Board who considers it to be an essential part of financial reporting for placing the basic financial statements in an appropriate operational, economic, or historical context. As part of our engagement, we will apply certain limited procedures to City of Lenoir's RSI in accordance with auditing standards generally accepted in the United States of America (GAAS). These limited procedures will consist of inquiries of management regarding the methods of preparing the information and comparing the information for consistency with management's responses to our inquiries, the basic financial statements, and other knowledge we obtained during our audit of the basic financial statements. We will not express an opinion or provide any assurance on the information because the limited procedures do not provide us with sufficient appropriate evidence to express an opinion or provide any assurance. The following RSI is required by GAAP and will be subjected to certain limited procedures, but will not be audited:

- 1) Management's Discussion and Analysis.
- 2) Schedule of Changes in Total Pension Liability – Law Enforcement Officers' Special Separation Allowance
- 3) Schedule of Total Pension Liability as a Percentage of Covered Payroll
- 4) Proportionate Share of Net Pension Liability (Asset)
- 5) City of Lenoir's Contributions – Local Government Retirement System
- 6) Schedule of Changes in Total OPEB Liability and Related Ratios

We have also been engaged to report on supplementary information other than RSI that accompanies City of Lenoir's financial statements. We will subject the following supplementary information to the auditing procedures applied in our audit of the financial statements and certain additional procedures, including comparing and reconciling such information directly to the underlying accounting and other records used to prepare the financial statements or to the financial statements themselves, and other additional procedures in accordance with GAAS, and we will provide an opinion on it in relation to the financial statements as a whole in a report combined with our auditor's report on the financial statements.

- 1) Schedule of Expenditures of Federal and State Awards.
- 2) Combining and Individual Fund Schedules

3) Schedules of Revenues, Expenditures, and Changes in Fund Balances – Budget and Actual

In connection with our audit of the basic financial statements, we will read the following other information and consider whether a material inconsistency exists between the other information and the basic financial statements, or the other information otherwise appears to be materially misstated. If, based on the work performed, we conclude that an uncorrected material misstatement of the other information exists, we are required to describe it in our report.

- 1) Schedule of Ad Valorem Taxes Receivable
- 2) Analysis of Current Tax Levy – City-Wide Level
- 3) Schedule of Cash and Investment Balance
- 4) Capital Assets Used in the Operation of Governmental Funds
- 5) Statistical Section

The objectives of our audit are to obtain reasonable assurance about whether the financial statements as a whole are free from material misstatement, whether due to fraud or error, and issue an auditor's report that includes our opinions about whether your financial statements are fairly presented, in all material respects, in conformity with GAAP, and report on the fairness of the supplementary information referred to in the second paragraph when considered in relation to the financial statements as a whole. Reasonable assurance is a high level of assurance but is not absolute assurance and therefore is not a guarantee that an audit conducted in accordance with GAAS and *Government Auditing Standards* will always detect a material misstatement when it exists. Misstatements, including omissions, can arise from fraud or error and are considered material if there is a substantial likelihood that, individually or in the aggregate, they would influence the judgment of a reasonable user made based on the financial statements. The objectives also include reporting on:

- Internal control over financial reporting and compliance with provisions of laws, regulations, contracts, and award agreements, noncompliance with which could have a material effect on the financial statements in accordance with *Government Auditing Standards*.
- Internal control over compliance related to major programs and an opinion (or disclaimer of opinion) on compliance with federal statutes, regulations, and the terms and conditions of federal and state awards that could have a direct and material effect on each major program in accordance with the Single Audit Act Amendments of 1996 and Title 2 U.S. *Code of Federal Regulations* (CFR) Part 200, *Uniform Administrative Requirements, Cost Principles, and Audit Requirements for Federal Awards* (Uniform Guidance).

Auditor's Responsibilities for the Audit of the Financial Statements and Single Audit

We will conduct our audit in accordance with GAAS; the standards for financial audits contained in *Government Auditing Standards*, issued by the Comptroller General of the United States; the Single Audit Act Amendments of 1996; and the provisions of the Uniform Guidance, and will include tests of accounting records, a determination of major program(s) in accordance with Uniform Guidance, and other procedures we consider necessary to enable us to express such opinions. As part of an audit in accordance with GAAS and *Government Auditing Standards*, we exercise professional judgment and maintain professional skepticism throughout the audit.

We will evaluate the appropriateness of the accounting policies used and the reasonableness of significant accounting estimates made by management. We will also evaluate the overall presentation of the financial statements, including the disclosures, and determine whether the financial statements represent the underlying transactions and events in a manner that achieves fair presentation. We will plan and perform the audit to obtain reasonable assurance about whether the financial statements are free of material misstatement, whether from (1) errors, (2) fraudulent financial reporting, (3) misappropriation of assets, or (4) violations of laws or governmental regulations that are attributable to the government or to acts by management or employees acting on behalf of the government. Because the determination of waste and abuse is subjective, *Government Auditing Standards* do not expect auditors to perform specific procedures to detect waste or abuse in financial audits nor do they expect auditors to provide reasonable assurance of detecting waste or abuse.

Because of the inherent limitations of an audit, combined with the inherent limitations of internal control, and because we will not perform a detailed examination of all transactions, there is an unavoidable risk that some material misstatements or noncompliance may not be detected by us, even though the audit is properly planned and performed in accordance with GAAS and *Government Auditing Standards*. In addition, an audit is not designed to detect immaterial misstatements or violations of laws or governmental regulations that do not have a direct and material effect on the financial statements or on major programs. However, we will inform the appropriate level of management of any material errors, any fraudulent financial reporting, or misappropriation of assets that come to our attention. We will also inform the appropriate level of management of any violations of laws or governmental regulations that come to our attention, unless clearly inconsequential. We will include such matters in the reports required for a Single Audit. Our responsibility as auditors is limited to the period covered by our audit and does not extend to any later periods for which we are not engaged as auditors.

In connection with this engagement, we may communicate with you or others via email transmission. As emails can be intercepted and read, disclosed, or otherwise used or communicated by an unintended third party, or may not be delivered to each of the parties to whom they are directed and only to such parties, we cannot guarantee or warrant that emails from us will be properly delivered and read only by the addressee. Therefore, we specifically disclaim and waive any liability or responsibility whatsoever for interception or unintentional disclosure of emails transmitted by us in connection with the performance of this engagement. In that regard, you agree that we shall have no liability for any loss or damage to any person or entity resulting from the use of email transmissions, including any consequential, incidental, direct, indirect, or special damages, such as loss of revenues or anticipated profits, or disclosure or communication of confidential or proprietary information.

We will also conclude, based on the audit evidence obtained, whether there are conditions or events, considered in the aggregate, that raise substantial doubt about the government's ability to continue as a going concern for a reasonable period of time.

Our procedures will include tests of documentary evidence supporting the transactions recorded in the accounts, tests of the physical existence of inventories, and direct confirmation of receivables and certain assets and liabilities by correspondence with selected individuals, funding sources, creditors, and financial institutions. We will also request written representations from your attorneys as part of the engagement.

We may, from time to time and depending on the circumstances, use third-party service providers in serving your account. We may share confidential information about you with these service providers but remain committed to maintaining the confidentiality and security of your information. Accordingly, we maintain internal policies, procedures, and safeguards to protect the confidentiality of your personal information. In addition, we will secure confidentiality agreements with all service providers to maintain the confidentiality of your information and we will take reasonable precautions to determine that they have appropriate procedures in place to prevent the unauthorized release of your confidential information to others. In the event that we are unable to secure an appropriate confidentiality agreement, you will be asked to provide your consent prior to the sharing of your confidential information with the third-party service provider. Furthermore, we will remain responsible for the work provided by any such third-party service providers.

Our audit of financial statements does not relieve you of your responsibilities.

Audit Procedures—Internal Control

We will obtain an understanding of the government and its environment, including the system of internal control, sufficient to identify and assess the risks of material misstatement of the financial statements, whether due to error or fraud, and to design and perform audit procedures responsive to those risks and obtain evidence that is sufficient and appropriate to provide a basis for our opinions. The risk of not detecting a material misstatement resulting from fraud is higher than for one resulting from error, as fraud may involve collusion, forgery, intentional omissions, misrepresentation, or the override of internal control. Tests of controls may be performed to test the effectiveness of certain controls that we consider relevant to preventing and detecting errors and fraud that are material to the financial statements and to preventing and detecting misstatements resulting from illegal acts and other noncompliance matters that have a direct and material effect on the financial statements. Our tests, if performed, will be less in scope than would be necessary to render an opinion on internal control and, accordingly, no opinion will be expressed in our report on internal control issued pursuant to *Government Auditing Standards*.

As required by the Uniform Guidance, we will perform tests of controls over compliance to evaluate the effectiveness of the design and operation of controls that we consider relevant to preventing or detecting material noncompliance with compliance requirements applicable to each major federal award program. However, our tests will be less in scope than would be necessary to render an opinion on those controls and, accordingly, no opinion will be expressed in our report on internal control issued pursuant to the Uniform Guidance.

An audit is not designed to provide assurance on internal control or to identify significant deficiencies or material weaknesses. Accordingly, we will express no such opinion. However, during the audit, we will communicate to management and those charged with governance internal control related matters that are required to be communicated under AICPA professional standards, *Government Auditing Standards*, and the Uniform Guidance.

Audit Procedures—Compliance

As part of obtaining reasonable assurance about whether the financial statements are free of material misstatement, we will perform tests of City of Lenoir's compliance with provisions of applicable laws, regulations, contracts, and agreements, including grant agreements. However, the objective of those procedures will not be to provide an opinion on overall compliance, and we will not express such an opinion in our report on compliance issued pursuant to *Government Auditing Standards*.

The Uniform Guidance requires that we also plan and perform the audit to obtain reasonable assurance about whether the auditee has complied with federal and state statutes, regulations, and the terms and conditions of federal and state awards applicable to major programs. Our procedures will consist of tests of transactions and other applicable procedures described in the *OMB Compliance Supplement* for the types of compliance requirements that could have a direct and material effect on each of City of Lenoir's major programs. For federal and state programs that are included in the Compliance Supplement, our compliance and internal control procedures will relate to the compliance requirements that the Compliance Supplement identifies as being subject to audit. The purpose of these procedures will be to express an opinion on City of Lenoir's compliance with requirements applicable to each of its major programs in our report on compliance issued pursuant to the Uniform Guidance.

Other Services

We will also assist in preparing the financial statements, schedule of expenditures of federal and state awards, and related notes of City of Lenoir in conformity with accounting principles generally accepted in the United States of America and the Uniform Guidance based on information provided by you. These nonaudit services do not constitute an audit under *Government Auditing Standards* and such services will not be conducted in accordance with *Government Auditing Standards*. We will perform the services in accordance with applicable professional standards. The other services are limited to the financial statements, schedule of expenditures of federal and state awards, and related notes services previously defined. We, in our sole professional judgment, reserve the right to refuse to perform any procedure or take any action that could be construed as assuming management responsibilities.

You agree to assume all management responsibilities for the financial statements, schedule of expenditures of federal and state awards, and related notes, and any other nonaudit services we provide. You will be required to acknowledge in the management representation letter our assistance with preparation of the financial statements, the schedule of expenditures of federal and state awards, and related notes and that you have reviewed and approved the financial statements, the schedule of expenditures of federal and state awards, and related notes prior to their issuance and have accepted responsibility for them. Further, you agree to oversee the nonaudit services by designating an individual, preferably from senior management, with suitable skill, knowledge, or experience; evaluate the adequacy and results of those services; and accept responsibility for them.

Responsibilities of Management for the Financial Statements and Single Audit

Our audit will be conducted on the basis that you acknowledge and understand your responsibility for (1) designing, implementing, establishing, and maintaining effective internal controls relevant to the preparation and fair presentation of financial statements that are free from material misstatement, whether due to fraud or error, including internal controls over federal and state awards, and for evaluating and monitoring ongoing activities to help ensure that appropriate goals and objectives are met; (2) following laws and regulations; (3) ensuring that there is reasonable assurance that government programs are administered in compliance with compliance requirements; and (4) ensuring that management and financial information is reliable and properly reported. Management is also

responsible for implementing systems designed to achieve compliance with applicable laws, regulations, contracts, and grant agreements. You are also responsible for the selection and application of accounting principles; for the preparation and fair presentation of the financial statements, schedule of expenditures of federal and state awards, and all accompanying information in conformity with accounting principles generally accepted in the United States of America; and for compliance with applicable laws and regulations (including federal and state statutes), rules, and the provisions of contracts and grant agreements (including award agreements). Your responsibilities also include identifying significant contractor relationships in which the contractor has responsibility for program compliance and for the accuracy and completeness of that information.

You are also responsible for making drafts of financial statements, schedule of expenditures of federal and state awards, all financial records, and related information available to us and for the accuracy and completeness of that information (including information from outside of the general and subsidiary ledgers). You are also responsible for providing us with (1) access to all information of which you are aware that is relevant to the preparation and fair presentation of the financial statements, such as records, documentation, identification of all related parties and all related-party relationships and transactions, and other matters; (2) access to personnel, accounts, books, records, supporting documentation, and other information as needed to perform an audit under the Uniform Guidance; (3) additional information that we may request for the purpose of the audit; and (4) unrestricted access to persons within the government from whom we determine it necessary to obtain audit evidence. At the conclusion of our audit, we will require certain written representations from you about the financial statements; schedule of expenditures of federal and state awards; federal and state award programs; compliance with laws, regulations, contracts, and grant agreements; and related matters.

Your responsibilities include adjusting the financial statements to correct material misstatements and confirming to us in the management representation letter that the effects of any uncorrected misstatements aggregated by us during the current engagement and pertaining to the latest period presented are immaterial, both individually and in the aggregate, to the financial statements of each opinion unit taken as a whole.

You are responsible for the design and implementation of programs and controls to prevent and detect fraud, and for informing us about all known or suspected fraud affecting the government involving (1) management, (2) employees who have significant roles in internal control, and (3) others where the fraud could have a material effect on the financial statements. Your responsibilities include informing us of your knowledge of any allegations of fraud or suspected fraud affecting the government received in communications from employees, former employees, grantors, regulators, or others. In addition, you are responsible for identifying and ensuring that the government complies with applicable laws, regulations, contracts, agreements, and grants. You are also responsible for taking timely and appropriate steps to remedy fraud and noncompliance with provisions of laws, regulations, contracts, and grant agreements that we report. Additionally, as required by the Uniform Guidance, it is management's responsibility to evaluate and monitor noncompliance with federal statutes, regulations, and the terms and conditions of federal and state awards; take prompt action when instances of noncompliance are identified including noncompliance identified in audit findings; promptly follow up and take corrective action on reported audit findings; and prepare a summary schedule of prior audit findings and a separate corrective action plan. The summary schedule of prior audit findings should be available for our review on December 15, 2026.

You are responsible for identifying all federal and state awards received and understanding and complying with the compliance requirements and for the preparation of the schedule of expenditures of federal and state awards (including notes and noncash assistance received, and COVID-19-related concepts, such as lost revenues, if applicable) in conformity with the Uniform Guidance. You agree to include our report on the schedule of expenditures of federal and state awards in any document that contains, and indicates that we have reported on, the schedule of expenditures of federal and state awards. You also agree to include the audited financial statements with any presentation of the schedule of expenditures of federal and state awards that includes our report thereon. Your responsibilities include acknowledging to us in the written representation letter that (1) you are responsible for presentation of the schedule of expenditures of federal and state awards in accordance with the Uniform Guidance; (2) you believe the schedule of expenditures of federal and state awards, including its form and content, is stated fairly in accordance with the Uniform Guidance; (3) the methods of measurement or presentation have not changed from those used in the prior period (or, if they have changed, the reasons for such changes); and (4) you have disclosed to us any significant assumptions or interpretations underlying the measurement or presentation of the schedule of expenditures of federal and state awards.

You are also responsible for the preparation of the other supplementary information, which we have been engaged to report on, in conformity with U.S. generally accepted accounting principles (GAAP). You agree to include our report on the supplementary information in any document that contains, and indicates that we have reported on, the supplementary information. You also agree to include the audited financial statements with any presentation of the supplementary information that includes our report thereon. Your responsibilities include acknowledging to us in the written representation letter that (1) you are responsible for presentation of the supplementary information in accordance with GAAP; (2) you believe the supplementary information, including its form and content, is fairly presented in accordance with GAAP; (3) the methods of measurement or presentation have not changed from those used in the prior period (or, if they have changed, the reasons for such changes); and (4) you have disclosed to us any significant assumptions or interpretations underlying the measurement or presentation of the supplementary information.

Management is responsible for establishing and maintaining a process for tracking the status of audit findings and recommendations. Management is also responsible for identifying and providing report copies of previous financial audits, attestation engagements, performance audits, or other studies related to the objectives discussed in the Audit Scope and Objectives section of this letter. This responsibility includes relaying to us corrective actions taken to address significant findings and recommendations resulting from those audits, attestation engagements, performance audits, or studies. You are also responsible for providing management's views on our current findings, conclusions, and recommendations, as well as your planned corrective actions for the report, and for the timing and format for providing that information.

With regard to publishing the financial statements on your website, you understand that websites are a means of distributing information and, therefore, we are not required to read the information contained in those sites or to consider the consistency of other information on the website with the original document.

Engagement Administration, Fees, and Other

SmartVault portal is used solely as a method of exchanging information and is not intended to store city of Lenoir's information. At the end of the engagement, C. Randolph CPA, PLLC will provide City of Lenoir with a copy (in an agreed-upon format) of deliverables and data related to the engagement from the SmartVault portal. For multi-year engagements, this exchange will occur annually.

Upon completion of the engagement, data and other content will either be removed from the SmartVault portal or become unavailable to C. Randolph CPA, PLLC within a reasonable time frame. For multi-year engagements, completion of the engagement occurs when the deliverables are completed for that year.

We understand that your employees will locate any documents selected by us for testing.

At the conclusion of the engagement, we will complete the appropriate sections of the Data Collection Form that summarize our audit findings. It is management's responsibility to electronically submit the reporting package (including financial statements, schedule of expenditures of federal and state awards, summary schedule of prior audit findings, auditor's reports, and corrective action plan) along with the Data Collection Form to the Federal Audit Clearinghouse. We will coordinate with you the electronic submission and certification. The Data Collection Form and the reporting package must be submitted within the earlier of 30 calendar days after receipt of the auditor's reports or nine months after the end of the audit period.

We will provide copies of our reports to the City; however, management is responsible for distribution of the reports and the financial statements. Unless restricted by law or regulation, or containing privileged and confidential information, copies of our reports are to be made available for public inspection.

The audit documentation for this engagement is the property of C. Randolph CPA, PLLC and constitutes confidential information. However, subject to applicable laws and regulations, audit documentation and appropriate individuals will be made available upon request and in a timely manner to the Local Government Commission or its designee, a federal or state agency providing direct or indirect funding, or the U.S. Government Accountability Office for purposes of a quality review of the audit, to resolve audit findings, or to carry out oversight responsibilities. We will notify you of any such request. If requested, access to such audit documentation will be provided under the supervision of C. Randolph CPA, PLLC personnel. Furthermore, upon request, we may provide

copies of selected audit documentation to the aforementioned parties. These parties may intend, or decide, to distribute the copies or information contained therein to others, including other governmental agencies.

The audit documentation for this engagement will be retained for a minimum of five years after the report release date or for any additional period requested by the Local Government Commission. If we are aware that a federal or state awarding agency, pass-through entity, or auditee is contesting an audit finding, we will contact the party(ies) contesting the audit finding for guidance prior to destroying the audit documentation.

Cynthia D. Randolph is the engagement CPA and is responsible for supervising the engagement and signing the reports.

Our audit engagement ends on delivery of our audit report. Any follow-up services that might be required will be a separate, new engagement. The terms and conditions of that new engagement will be governed by a new, specific engagement letter for that service.

Our fee for these services will be at our standard hourly rates plus out-of-pocket costs (such as report reproduction, word processing, postage, travel, copies, telephone, confirmation service provider fees, etc.) except that we agree that our gross fee, including expenses, will not exceed \$45,000. Our standard hourly rates vary according to the degree of responsibility involved and the experience level of the personnel assigned to your audit. Our invoices for these fees will be rendered each month as work progresses and are payable on presentation. In accordance with our firm policies, work may be suspended if your account becomes 30 days or more overdue and may not be resumed until your account is paid in full. If we elect to terminate our services for nonpayment, our engagement will be deemed to have been completed upon written notification of termination, even if we have not completed our report(s). You will be obligated to compensate us for all time expended and to reimburse us for all out-of-pocket costs through the date of termination. The above fee is based on anticipated cooperation from your personnel and the assumption that unexpected circumstances will not be encountered during the engagement. If significant additional time is necessary, we will keep you informed of any problems we encounter and our fees will be adjusted accordingly.

Reporting

We will issue written reports upon completion of our Single Audit. Our reports will be addressed to the Honorable Mayor and City Council of City of Lenoir.

We will make reference to Lowdermilk Church & Co., LLP's audit of City of Lenoir ABC Board in our report on your financial statements.

Circumstances may arise in which our report may differ from its expected form and content based on the results of our audit. Depending on the nature of these circumstances, it may be necessary for us to modify our opinions, add a separate section, or add an emphasis-of-matter or other-matter paragraph to our auditor's report, or if necessary, withdraw from this engagement. If our opinions are other than unmodified, we will discuss the reasons with you in advance. If, for any reason, we are unable to complete the audit or are unable to form or have not formed opinions, we may decline to express opinions or issue reports, or we may withdraw from this engagement.

The *Government Auditing Standards* report on internal control over financial reporting and on compliance and other matters will state that (1) the purpose of the report is solely to describe the scope of testing of internal control and compliance and the results of that testing, and not to provide an opinion on the effectiveness of the entity's internal control or on compliance, and (2) the report is an integral part of an audit performed in accordance with *Government Auditing Standards* in considering the entity's internal control and compliance. The Uniform Guidance report on internal control over compliance will state that the purpose of the report on internal control over compliance is solely to describe the scope of testing of internal control over compliance and the results of that testing based on the requirements of the Uniform Guidance. Both reports will state that the report is not suitable for any other purpose.

We appreciate the opportunity to be of service to the City of Lenoir and believe this letter accurately summarizes the significant terms of our engagement. If you have any questions, please let us know. If you agree with the terms of our engagement as described in this letter, please sign the attached copy and return it to us.

You have requested that we provide you with a copy of our most recent external peer review report and any subsequent reports received during the contract period. Accordingly, our 2024 peer review report accompanies this letter.

Very truly yours,

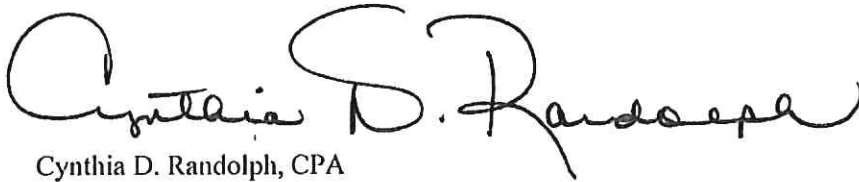

Cynthia D. Randolph, CPA

RESPONSE:

This letter correctly sets forth the understanding of City of Lenoir.

Management signature: ✓ Scott Hill

Title: ✓ City Manager

Date: ✓ Feb 17, 2026

Governance signature: ✓ Joseph R. Hill

Title: ✓ Mayor

Date: ✓ Feb 17, 2026

LGC-205 Form A

CONTRACT TO AUDIT ACCOUNTS

Rev. 02/2026

The of and	Governing Board Honorable Mayor and City Council
	Primary Government Unit City of Lenoir
	Discretely Presented Component Unit (DPCU) (if applicable) N/A

Primary Government Unit, together with DPCU (if applicable), hereinafter referred to as Governmental Unit(s)

and	Auditor Name C. Randolph CPA, PLLC
	Auditor Address 560 Beaver Creek School Rd., West Jefferson, NC 28694

Hereinafter referred to as Auditor

for	Fiscal Year Ending 06/30/26	Date Audit Will Be Submitted to LGC 12/31/26
-----	--------------------------------	---

Must be within six months of FYE

hereby agree as follows:

1. The Auditor shall audit all statements and disclosures required by "U.S. Auditing Standards – AICPA (Clarified)," referred to as generally accepted auditing standards (GAAS) and additional required legal statements and disclosures of all funds and/or divisions of the Governmental Unit(s). The non-major combining, and individual fund statements and schedules shall be subjected to the auditing procedures applied in the audit of the basic financial statements and an opinion shall be rendered in relation to (as applicable) the governmental activities, the business-type activities, the aggregate DPCUs, each major governmental and enterprise fund, and the aggregate remaining fund information (non-major government and enterprise funds, the internal service fund type, and the fiduciary fund types). Budgetary comparison information shall be prepared in accordance with applicable GASB standards. Budget-to-actual comparisons at the level of the legally adopted budget ordinance shall be presented as required supplementary information and shall not be included in the basic financial statements. Any other budgetary comparison information shall be presented only as supplementary information for funds required to be budgeted under NCGS Chapter 159, Article 3.

2. At a minimum, the Auditor shall conduct the audit and render the report in accordance with GAAS. If the Governmental Unit expended \$100,000 or more in combined Federal and State financial assistance during the reporting period, the Auditor shall perform the audit in accordance with *Generally Accepted Government Auditing Standards* (GAGAS). The Governmental Unit is subject to federal single audit requirements in accordance with Title 2 US Code of Federal Regulations Part 200 *Uniform Administration Requirements, Cost Principles, and Audit Requirements for Federal Awards*, Subpart F (*Uniform Guidance*) and the State Single Audit Implementation Act. Currently the threshold is \$1,000,000 for federal and state single audits, or such other threshold as applicable for the fiscal year under audit. This audit and all associated audit documentation may be subject to review by federal and State agencies in accordance with federal and State laws, including the staff of the Office of State Auditor (OSA) and the Local Government Commission (LGC). If the audit requires a federal single audit in accordance with the Uniform Guidance (§200.501) the Auditor and Governmental Unit(s) should discuss, in advance of the execution of this contract, the responsibility for submission of the audit and the accompanying data collection form (form SF-FAC) to the Federal Audit Clearinghouse as required under the Uniform Guidance (§200.512) to ensure proper submission.

If the audit and Auditor communication are found in this review to be substandard, the results of the review may be forwarded to the North Carolina State Board of CPA Examiners (NC State Board).

LGC-205 Form A

CONTRACT TO AUDIT ACCOUNTS

Rev. 02/2026

3. If an entity is determined to be a component of another government as defined by the group audit standards, the entity's auditor shall make a good faith effort to comply in a timely manner with the requests of the group auditor in accordance with AU-6 §600.41 - §600.42.

4. This contract contemplates an unmodified opinion being rendered. If during the process of conducting the audit, the Auditor determines that it will not be possible to render an unmodified opinion on the financial statements of the unit, the Auditor shall contact the LGC Staff to discuss the circumstances leading to that conclusion as soon as is practical and before the final report is issued. The audit shall include such tests of the accounting records and such other auditing procedures as are considered by the Auditor to be necessary in the circumstances. Any limitations or restrictions in scope which would lead to a qualification should be fully explained in an attachment to this contract.

5. If this audit engagement is subject to the standards for audit as defined in *Government Auditing Standards* (2018 revision or subsequent revisions, as applicable) issued by the Comptroller General of the United States, then by accepting this engagement, the Auditor warrants that he or she has met the requirements for a peer review and continuing education as specified in *Government Auditing Standards*. The Auditor agrees to provide a copy of the most recent peer review report to the Governmental Unit(s) and to the Secretary of the LGC prior to the execution of an audit contract. Subsequent submissions of the report are required only upon report expiration or upon the Auditor's receipt of an updated peer review report. If the audit firm receives a peer review rating other than pass, the Auditor shall not contract with the Governmental Unit(s) without first contacting the Secretary of the LGC for a peer review analysis that may result in additional contractual requirements.

If the audit engagement is not subject to *Government Auditing Standards* or if financial statements are not prepared in accordance with U.S. generally accepted accounting principles (GAAP) and fail to include all disclosures required by GAAP, the Auditor shall provide an explanation as to why in an attachment to this contract or in an amendment.

6. It is agreed that time is of the essence in this contract. All audits are to be performed, and the report of audit submitted to LGC Staff, within six months of fiscal year end. At the time of the execution of this contract, if the parties know that the anticipated submission date of the audit exceeds six months after fiscal year end, a written explanation shall be provided to the Secretary of the LGC on this contract form (see the space provided on Page 7). If it becomes necessary to amend the audit fee or the date that the audit report will be submitted to the LGC, an amended contract along with a written explanation of the change shall be submitted to the Secretary of the LGC for approval.

7. It is agreed that GAAS include a review of the Governmental Unit's (Units') systems of internal control and accounting as they relate to accountability of funds and adherence to budget and law requirements applicable thereto; that the Auditor shall make a written report, which may or may not be a part of the written report of audit, to the Governing Board setting forth the Auditor's findings, together with his or her recommendations for improvement. That written report shall include all matters determined to be "significant deficiencies and material weaknesses" in accordance with AU-C §265 "Communicating Internal Control Related Matters Identified in an Audit" of GAAS. The Auditor shall file a copy of that report with the Secretary of the LGC.

For GAAS or *Government Auditing Standards* audits, if an Auditor issues an AU-C §260 report, "Auditor's Communication With Those Charged With Governance," commonly referred to as a "Governance Letter," LGC staff does not require the report to be submitted unless the Auditor cites significant findings or issues from the audit, as defined in AU-C §260 paragraphs 12 - 14. This would include issues such as difficulties encountered during the audit, significant or unusual transactions, uncorrected misstatements, matters that are difficult or contentious for which the Auditor consulted outside the engagement team and, in the Auditor's judgment, are significant and relevant to those charged with governance, and other findings or issues that the Auditor believes are significant and relevant. If matters identified during the audit were required to be reported as described in AU-C §260 paragraphs 12 - 14 and were communicated in a method other than an AU-C §260 letter, the written documentation must be submitted.

LGC-205 Form A

CONTRACT TO AUDIT ACCOUNTS

Rev. 02/2026

8. All local government and public authority contracts for audit or audit-related work require the approval of the Secretary of the LGC. This includes annual or special audits, agreed upon procedures related to internal controls, bookkeeping or other assistance necessary to prepare the Governmental Unit's records for audit, financial statement preparation, any finance-related investigations, or any other audit-related work in the State of North Carolina. Approval is also required for the Alternative Compliance Examination Engagement for auditing the Coronavirus State and Local Fiscal Recovery Funds expenditures as allowed by US Treasury. Approval is not required on audit contracts and invoices for system improvements and similar services of a non-auditing nature.

9. Invoices for services rendered under these contracts shall not be paid by the Governmental Unit(s) until the invoice has been approved by the Secretary of the LGC. This also includes any progress billings [G.S. 159-34 and 115C-447]. All invoices for audit work shall be submitted in PDF format to the Secretary of the LGC for approval. The invoice marked 'approved' with approval date shall be returned to the Auditor to present to the Governmental Unit(s) for payment. This paragraph is not applicable to contracts for audits of hospitals.

10. In consideration of the satisfactory performance of the provisions of this contract, the Governmental Unit(s) shall pay to the Auditor, upon approval by the Secretary of the LGC if required, the fee, which includes any costs the Auditor may incur from work paper or peer reviews or any other quality assurance program required by third parties (federal and state grantor and oversight agencies or other organizations) as required under the Federal Single Audit Act and the State Single Audit Act. This does not include fees for any pre-issuance reviews that may be required by the North Carolina Association of Certified Public Accountants (NCACPA) Peer Review Committee or North Carolina State Board of CPA Examiners (see Paragraph 13).

11. If the Governmental Unit(s) has/have outstanding revenue bonds, the Auditor shall submit to LGC Staff, either in the notes to the audited financial statements or as a separate report, a calculation demonstrating compliance with the revenue bond rate covenant. Additionally, the Auditor shall submit to LGC Staff simultaneously with the Governmental Unit's (Units') audited financial statements any other bond compliance statements or additional reports required by the authorizing bond documents, unless otherwise specified in the bond documents.

12. After completing the audit, the Auditor shall submit to the Governing Board a written report of audit. This report shall include, but not be limited to, the following information: (a) Management's Discussion and Analysis, (b) the financial statements and notes of the Governmental Unit(s) and all of its component units prepared in accordance with GAAP, (c) supplementary information requested by the Governmental Unit(s) or required for full disclosure under the law, and (d) the Auditor's opinion on the material presented. The Auditor shall furnish the required number of copies of the report of audit to the Governing Board upon completion.

13. If the audit firm is required by the Secretary of the Local Government Commission to obtain a pre-issuance review or take corrective action as a result of peer review findings or quality control deficiencies, such corrective action shall be consistent with the authority and requirements of the North Carolina State Board of Certified Public Accountant Examiners, the AICPA Peer Review Program, and established Local Government Commission practice, including the use of report addenda or other remedial measures, as appropriate.

LGC-205 Form A

CONTRACT TO AUDIT ACCOUNTS

Rev. 02/2026

14. In accordance with G.S. 159-34, the Finance Officer of the Unit is responsible for filing the audited financial statements with the Secretary of the Local Government Commission.

The Auditor may upload the audit report and related documents through the LGC's electronic submission system; however, submission shall not be deemed complete until the Finance Officer has reviewed and certified the submission.

The Auditor, Finance Officer, other Unit staff member designated by the Finance Officer, or a third party approved by the Unit may enter all Data Input Report information except the information on the "transmittal doc info" tab. The "transmittal doc info" tab must be completed by the Auditor.

The Finance Officer shall review, approve, and certify the accuracy and completeness of the Data Input Report (DIR) in the LGC's LOGOS system prior to LGC review, regardless of whether the DIR is prepared by the Auditor or the Unit.

Finance Officer certification is required for any corrected or revised submissions.

Finance Officer certification of the DIR shall be completed in a timely manner following notification that the DIR is ready for review and within time frames prescribed by the LGC. Failure to complete certification in a timely manner may result in the audit being considered late due to unit action rather than auditor performance

The Auditor shall conduct the audit in accordance with generally accepted auditing standards and shall ensure that the financial statements are prepared in accordance with generally accepted accounting principles as of the fiscal year end. Budget-to-actual comparisons at the level of the legally adopted budget ordinance shall be presented in required supplementary information, separate from the basic financial statements, and shall not be included in the audit opinion. The Auditor shall confirm that such information reconciles to the financial statements and is consistent with applicable accounting guidance and any LGC reporting requirements.

The Finance Officer shall certify in a timely manner that all data inputted in LOGOS used for preparation of the financial statements and required supplementary information is complete and accurate.

For audits of units other than hospitals, the audit report should be submitted when (or prior to) submitting the final invoice for services rendered. The report of audit, as filed with the Secretary of the LGC, becomes a matter of public record for inspection, review and copy in the offices of the LGC by any interested parties. Any subsequent revisions to these reports shall be sent to the Secretary of the LGC. These audited financial statements, excluding the Auditors' opinion, may be used in the preparation of official statements for debt offerings by municipal bond rating services to fulfill secondary market disclosure requirements of the Securities and Exchange Commission and for other lawful purposes of the Governmental Unit(s) without requiring consent of the Auditor. If the LGC Staff determines that corrections need to be made to the Governmental Unit's (Units') financial statements and/or the compliance section, those corrections shall be provided within three business days of notification unless another deadline is agreed to by LGC Staff.

LGC-205 Form A

CONTRACT TO AUDIT ACCOUNTS

Rev. 02/2026

15. Should circumstances disclosed by the audit call for a more detailed investigation by the Auditor than necessary under ordinary circumstances, the Auditor shall inform the Governing Board in writing of the need for such additional investigation and the additional compensation required therefore. Upon approval by the Secretary of the LGC, this contract may be modified or amended to include the increased time, compensation, or both as may be agreed upon by the Governing Board and the Auditor.
16. If an approved contract needs to be modified or amended for any reason, the change shall be made in writing and preaudited if the change includes a change in audit fee (preaudit requirement does not apply to hospitals). This amended contract shall be completed in full, including a written explanation of the change, signed and dated by all original parties to the contract. It shall then be submitted to the Secretary of the LGC for approval. No change to the audit contract shall be effective unless approved by the Secretary of the LGC.
17. A copy of the engagement letter, issued by the Auditor and signed by both the Auditor and the Governmental Unit(s), shall be attached to this contract, and except for fees, work, and terms not related to audit services, shall be incorporated by reference as if fully set forth herein as part of this contract. In case of conflict between the terms of the engagement letter and the terms of this contract, the terms of this contract shall take precedence. Engagement letter terms that conflict with the contract are deemed to be void unless the conflicting terms of this contract are specifically deleted in Paragraph 30 of this contract. Engagement letters containing indemnification clauses shall not be accepted by LGC Staff.
18. Special provisions should be limited. Please list any special provisions in an attachment.
19. A separate contract should not be made for each division to be audited or report to be submitted. If a DPCU is subject to the audit requirements detailed in The Local Government Budget and Fiscal Control Act and a separate audit report is issued, a separate audit contract is required. If a separate report is not to be issued and the DPCU is included in the primary government audit, the DPCU shall be named along with the primary government on this audit contract. DPCU Board approval date, signatures from the DPCU Board chairman and Finance Officer also shall be included on this contract.
20. The contract shall be executed, preaudited (preaudit requirement does not apply to hospitals) and physically signed by all parties including Governmental Unit(s) and the Auditor, then submitted in PDF format to the Secretary of the LGC.
21. The contract is not valid until it is approved by the Secretary of the LGC. The staff of the LGC shall notify the Governmental Unit and Auditor of contract approval by email. The audit should not be started before the contract is approved.
22. Retention of Client Records: Auditors are subject to the NC State Board of CPA Examiners' Retention of Client Records Rule 21 NCAC 08N .0305 as it relates to the provision of audit and other attest services, as well as non-attest services. Clients and former clients should be familiar with the requirements of this rule prior to requesting the return of records.

LGC-205 Form A

CONTRACT TO AUDIT ACCOUNTS

Rev. 02/2026

23. This contract may be terminated at any time by mutual consent and agreement of the Governmental Unit(s) and the Auditor, provided that (a) the consent to terminate is in writing and signed by both parties, (b) the parties have agreed on the fee amount which shall be paid to the Auditor (if applicable), and (c) no termination shall be effective until approved in writing by the Secretary of the LGC.

24. The Governmental Unit's (Units') failure or forbearance to enforce, or waiver of, any right or an event of breach or default on one occasion or instance shall not constitute the waiver of such right, breach or default on any subsequent occasion or instance.

25. There are no other agreements between the parties hereto and no other agreements relative hereto that shall be enforceable unless entered into in accordance with the procedure set out herein and approved by the Secretary of the LGC.

26. E-Verify. The Auditor shall comply with the requirements of NCGS Chapter 64 Article 2. Further, if the Auditor utilizes any subcontractor(s), Auditor shall require such subcontractor(s) to comply with the requirements of NCGS Chapter 64, Article 2.

27. For all non-attest services, the Auditor shall adhere to the independence rules of the AICPA Professional Code of Conduct and *Government Auditing Standards, 2018 or 2024 Revision* (as applicable). Preparing financial statements in their entirety shall be deemed a "significant threat" requiring the Auditor to apply safeguards sufficient to reduce the threat to an acceptable level. If the Auditor cannot reduce the threats to an acceptable level, the Auditor cannot complete the audit. If the Auditor is able to reduce the threats to an acceptable level, the documentation of this determination, including the safeguards applied, must be included in the audit workpapers.

All non-attest service(s) being performed by the Auditor that are necessary to perform the audit must be identified and included in this contract. The Governmental Unit shall designate an individual with the suitable skills, knowledge, and/or experience (SKE) necessary to oversee the services and accept responsibility for the results of the services performed. If the Auditor is able to identify an individual with the appropriate SKE, the Auditor must document and include in the audit workpapers how the Auditor reached that conclusion. If the Auditor determines that an individual with the appropriate SKE cannot be identified, the Auditor cannot perform both the non-attest service(s) and the audit. See "Fees for Audit Services" page of this contract to disclose the person identified as having the appropriate SKE for the Governmental Unit.

28. **Applicable to audits with fiscal year ends of June 30, 2021 and later.** The Auditor shall present the audited financial statements including any compliance reports to the Government Unit's Governing Board or audit committee in an official meeting in open session as soon as the audited financial statements are available but not later than 45 days after the submission of the audit report to the Secretary of the LGC. The Auditor's presentation to the Governing Board or audit committee shall include:

- a) the description of each finding, including all material weaknesses and significant deficiencies, as found by the Auditor, and any other issues related to the internal controls or fiscal health of the Government Unit as disclosed in the management letter, the Single Audit or Yellow Book reports, or any other communications from the Auditor regarding internal controls as required by current auditing standards;
- b) the status of the prior year audit findings;
- c) the values of Financial Performance Indicators based on information presented in the audited financial statements; and
- d) notification to the Governing Board that the Governing Board shall develop a "Response to the Auditor's Findings, Recommendations, and Fiscal Matters," if required under Rule 20 NCAC 03 .0508.

LGC-205 Form A

CONTRACT TO AUDIT ACCOUNTS

Rev. 02/2026

29. Information based on the audited financial statements shall be submitted to the Secretary of the LGC through the LGC's LOGOS system, including completion of the Data Input Report (DIR). Submission is not complete and shall not be accepted by the LGC until the Finance Officer has reviewed and certified the DIR in accordance with Paragraph 14 of this contract.

30. All of the above paragraphs are understood and shall apply to this contract, except the following numbered paragraphs shall be deleted (See Paragraph 17 for clarification). #26

31. The process for submitting contracts, audit reports and invoices is subject to change. Auditors and Units should use the submission process and instructions in effect at the time of submission. Refer to the N.C. Department of State Treasurer website at <https://www.nctreasurer.com/state-and-local-government-finance-division/local-government-commission/submitting-your-audit>.

32. All communications regarding audit contract requests for modification or official approvals will be sent to the email addresses provided on the signature pages that follow.

33. **Applicable to audits with fiscal year ends of June 30, 2025, and later.** The Unit authorizes the LGC to grant access to the LGC's LOGOS system, including the Data Input Report (DIR), to employees of the contracted audit firm who are associated with and acting on behalf of the firm for purposes of performing audit and reporting services under this contract. Such access shall be limited to the scope necessary to perform contracted services and shall not relieve the Auditor or the Unit of their respective responsibilities under this contract.

34. Changes or edits to the text of this contract form are not permitted, except for the Secretary's authority to revise or update this contract form pursuant to LGC Rule 20 NCAC 03. 0502.

For contracts with an anticipated audit submission date exceeding six months after fiscal year end, please use this space to explain the reason for the late submission, as required by Paragraph 6 of this contract form:

LGC-205 Form B

CONTRACT TO AUDIT ACCOUNTS

Rev. 02/2026

FEEES FOR AUDIT SERVICES

1. For all non-attest services, the Auditor shall adhere to the independence rules of the AICPA Professional Code of Conduct (as applicable) and *Government Auditing Standards, 2018 Revision*. Refer to Paragraph 27 of this contract for specific requirements. The following information must be provided by the Auditor; contracts presented to the LGC without this information will be not be approved.

Financial statements were prepared by: Auditor Governmental Unit Third Party

If applicable: The individual at the Governmental Unit designated to have the suitable skills, knowledge, and/or experience (SKE) necessary to oversee the non-attest services and accept responsibility for the results of these services:

Name:	Title and Unit / Company:	Email Address:
Donna Bean	Finance Officer	dbean@ci.lenoir.nc.us

OR Not Applicable (Identification of SKE Individual on the LGC-205 Contract is not applicable for GAAS-only audits or audits with FYEs prior to June 30, 2020.)

2. Fees may not be included in this contract for work performed on Annual Financial Information Reports (AFIRs), Form 990s, or other services not associated with audit fees and costs. Such fees may be included in the engagement letter but may not be included in this contract or in any invoices requiring approval of the LGC. See Paragraphs 8 and 13 for details on other allowable and excluded fees.

3. The audit fee information included in the table below for both the Primary Government Fees and the DPCU Fees (if applicable) should be reported as a specific dollar amount of audit fees for the year under this contract. If any language other than an amount is included here, the contract will be returned to the audit firm for correction.

4. Prior to the submission of the completed audited financial report and applicable compliance reports subject to this contract, or to an amendment to this contract (if required) the Auditor may submit interim invoices for approval for services rendered under this contract to the Secretary of the LGC, not to exceed 75% of the billings for the Unit's last annual audit that was submitted to the Secretary of the LGC. All invoices for services rendered in an audit engagement as defined in Rule 20 NCAC .0503 shall be submitted to the Secretary of the LGC for approval before any payment is made. Payment before approval is a violation of law. (This paragraph not applicable to contracts and invoices associated with audits of hospitals).

Primary Government Unit	City of Lenoir	
Audit Fee (financial and compliance if applicable)	\$	34,000
Fee per Major Program (if not included above)	\$	
Additional Fees Not Included Above (if applicable):		
Financial Statement Preparation (incl. notes and RSI)	\$	9,500
All Other Non-Attest Services	\$	1,500
TOTAL AMOUNT NOT TO EXCEED	\$	45,000

Discretely Presented Component Unit	N/A	
Audit Fee (financial and compliance if applicable)	\$	
Fee per Major Program (if not included above)	\$	
Additional Fees Not Included Above (if applicable):		
Financial Statement Preparation (incl. notes and RSI)	\$	
All Other Non-Attest Services	\$	
TOTAL AMOUNT NOT TO EXCEED	\$	

LGC-205 Form B

CONTRACT TO AUDIT ACCOUNTS

Rev. 02/2026

SIGNATURE PAGE

AUDIT FIRM

Audit Firm* C. Randolph CPA, PLLC	
Authorized Firm Representative (typed or printed)* Cynthia D. Randolph	Signature* 
Date* 02/06/26	Email Address* cindy@crandolphcpa.com

GOVERNMENTAL UNIT

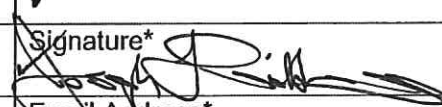
Governmental Unit* City of Lenoir	
Date Governing Board Approved Audit Contract* (Enter date in box to right)	<input checked="" type="checkbox"/>
Mayor/Chairperson (typed or printed)* Joseph L. Gibbons	Signature* 
Date <input checked="" type="checkbox"/> Feb 17, 2026	Email Address* josephlgibbons@yahoo.com

Chair of Audit Committee (typed or printed, or "NA") N/A	Signature \
Date	Email Address

GOVERNMENTAL UNIT – PREAUDIT CERTIFICATE

Required by G.S. 159-28(a1) or G.S. 115C-441(a1). Not applicable to hospital contracts.

This instrument has been preaudited in the manner required by The Local Government Budget and Fiscal Control Act or by The School Budget and Fiscal Control Act.

Sum Obligated by This Transaction:	\$ 45,000
Primary Governmental Unit Finance Officer* (typed or printed) Donna Bean	Signature* <input checked="" type="checkbox"/> Donna Bean
Date of Preaudit Certificate* <input checked="" type="checkbox"/> Donna Bean	Email Address* dbean@ci.lenoir.nc.us

LGC-205 Form B

CONTRACT TO AUDIT ACCOUNTS

Rev. 02/2026

**SIGNATURE PAGE – DPCU
 (complete only if applicable)**

DISCRETELY PRESENTED COMPONENT UNIT

DPCU* N/A	
Date DPCU Governing Board Approved Audit Contract* (Enter date in box to right)	
DPCU Chairperson (typed or printed)*	Signature*
Date*	Email Address*

Chair of Audit Committee (typed or printed, or "NA") N/A	Signature
Date	Email Address

DPCU – PREAUDIT CERTIFICATE

Required by G.S. 159-28(a1) or G.S. 115C-441(a1). Not applicable to hospital contracts.

This instrument has been preaudited in the manner required by The Local Government Budget and Fiscal Control Act or by The School Budget and Fiscal Control Act.

Sum Obligated by this Transaction:	\$
DPCU Finance Officer (typed or printed)*	Signature*
Date of Preaudit Certificate*	Email Address*

Remember to print this form, and obtain all required signatures prior to submission.

PRINT

REQUEST TO SURPLUS CITY PROPERTY

Department Requesting Disposal of Surplus Property	
Date of Request	2/4/2026
Department Name	Police Department
Contact Name	Chief Andy Wilson
Phone	828-757-2100

ITEM	QTY	CODE*	SERIAL/VIN #	MAKE	MODEL YEAR	MILEAGE/ MACHINE HOURS	REASON FOR REQUEST	CURRENT LOCATION OF THE ITEM	ORIGINAL PURCHASE PRICE	DATE OF PURCHASE	ESTIMATED SALVAGE VALUE	ITEM IN WORKING ORDER Y/N	APPROVED TO LIST ON GOVDEALS
Sig Sauer P-320 Pistol	1	S1	58J472282	Sig Sauer			Sgt. Spears Retirement	PD	\$ 764.00	9/1/23		Y	<input type="checkbox"/>
Police Badge (Sgt. Spears)	1	S1	N/A	Blackinton			Retirement	PD	\$ 128.00	Unk		Y	<input type="checkbox"/>
Retirement of Sgt. Matt Spears													<input type="checkbox"/>
													<input type="checkbox"/>
													<input type="checkbox"/>

** Please enter one CODE per item: (S1) Obsolete (S2) Too Costly to Maintain (S3) Beyond Repair (S4) Cannibalized*

APPROVED BY	DATE

ITEM	DATE OF SALE	SELLING PRICE	DATE OF DEPOSIT	BUDGET CODE FOR DEPOSIT	DATE ITEM REMOVED FROM INVENTORY		BY WHOM - SIGNATURE	DATE ITEM REMOVED FROM INSURANCE	BY WHOM - SIGNATURE	DATE TAG CANCELLED OR TRANSFERRED	BY WHOM - SIGNATURE

ALL SURPLUS ITEMS ARE LISTED ON GOVDEALS IN ACCORDANCE WITH CITY OF LENOIR RESOLUTION NO. 6-2007, NC GENERAL STATUTES 160A-270 AND NCGS 160A-270 (c)



CITY MANAGER
SCOTT E. HILDEBRAN

CITY OF LENOIR
NORTH CAROLINA

MAYOR
JOSEPH L. GIBBONS

CITY COUNCIL
J. T. BEAL
R.C. DELLINGER
J. I. PERKINS
R. S. PRESTWOOD
K. R. ROGERS
D. F. STEVENS
C. D. THOMAS

**RESOLUTION AFFIRMING THE CITY OF LENOIR COUNCIL'S SUPPORT
REGARDING IMPLEMENTATION OF A COMPLIANT NPDES MS4 STORMWATER PROGRAM**

A RESOLUTION to develop and implement a compliant stormwater management program that meets the requirements of the CITY OF LENOIR National Pollutant Discharge Elimination System (NPDES) Municipal Separate Storm Sewer System (MS4) Permit number NCS000474 to discharge stormwater, inclusive of the required Stormwater Management Plan to be prepared by the CITY OF LENOIR and approved by the North Carolina Department of Environmental Quality.

WHEREAS, Section 402(p) of the federal Clean Water Act requires NPDES permits for stormwater discharges from municipal separate storm sewer systems; and

WHEREAS, in North Carolina, NPDES Permits are issued by the North Carolina Department of Environmental Quality; and

WHEREAS, the North Carolina Department of Environmental Quality issued the CITY OF LENOIR its third NPDES MS4 Permit for discharge of stormwater on July 1, 2021; and

WHEREAS, the CITY OF LENOIR was issued Notice of Violation number NOV-2026-PC-0040 on February 2, 2026 for noncompliance with the issued NPDES MS4 Permit; and

WHEREAS, the CITY OF LENOIR acknowledges the specific Notice of Violation requirement to obtain a new individual NPDES MS4 Permit; and

WHEREAS, the CITY OF LENOIR acknowledges the specific Notice of Violation requirement to conduct a self-audit of permit compliance for the balance of permit requirements not specifically audited by the North Carolina Department of Environmental Quality, and to develop a draft Stormwater Management Plan to comply with Section 402(p)(3)(B)(iii) of the Clean Water Act, 40 CFR 122.34(b) and NPDES MS4 Permit requirements, and to submit its draft Stormwater Management Plan to the North Carolina Department of Environmental Quality no later than 120 Days from February 2, 2026 for review and approval; and

WHEREAS, the CITY OF LENOIR acknowledges the specific Notice of Violation requirement to adopt a Council Resolution to implement a compliant and enforceable stormwater management program as defined by both the NPDES MS4 Permit number NCS000474 and the required new Stormwater Management Plan, and said resolution is to be submitted to the North Carolina Department of Environmental Quality no later than 60 Days from February 2, 2026; and



WHEREAS, the CITY OF LENOIR acknowledges the requirement to provide adequate funding and staffing to implement a Stormwater Management Program that complies with its NPDES MS4 Permit and approved Stormwater Management Plan; and

WHEREAS, the CITY OF LENOIR acknowledges that North Carolina Department of Environmental Quality enforcement action and penalties could result from non-compliance with the specific requirements in Notice of Violation number NOV-2026-PC-0040; and

WHEREAS, the CITY OF LENOIR acknowledges that any North Carolina Department of Environmental Quality enforcement action and penalties may not prohibit the U.S. Environmental Protection Agency from taking its own enforcement action for non-compliance with the issued NPDES MS4 Permit.

NOW, THEREFORE, BE IT RESOLVED that the Council of the CITY OF LENOIR hereby affirms its support for development and implementation of a compliant NPDES MS4 Stormwater Program.



Joe Gibbons, Mayor

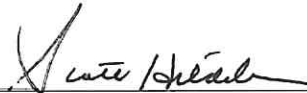

Scott Hildebran, City Manager



Alison Adams, Stormwater Program
Administrator

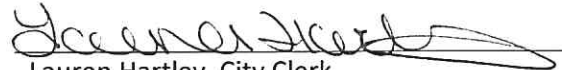

Lauren Hartley, City Clerk

ADOPTED BY the City Council of the CITY OF LENOIR, North Carolina the 17th day of February, 2026 and signed in authentication thereof the 17th day of February, 2026.

COMMITTEE OF THE WHOLE
MEETING MINUTES
Tuesday, February 24, 2026
8:30 A.M.

Present: Mayor Joe Gibbons, Mayor Pro-Tem Ike Perkins, Councilmembers Jonathan Beal, Rebecca Dellinger, Ralph Prestwood, Kimmie Rogers, Chrissy Thomas, David Stevens.

Staff Present: City Manager Scott Hildebran, City Clerk Lauren Hartley, Finance Director Donna Bean, Planning Director Hannah Williams, Public Services Public Works Director Jon Hogan, Interim Director of Special Projects & Grants & Risk Management/Purchasing David Coffey, Communications & Public Information Director Joshua Harris, Police Chief Andy Wilson, Economic & Main Street Director Brenda Floyd, Public Services Public Utilities Director Jeff Church, Parks & Recreation Director Phil Harper, Fire Chief Norman Staines, Community Engagement Coordinator Ashley Smith, Major Chris Bumgarner.

I. CALL TO ORDER

Mayor Pro-Tem Ike Perkins welcomed everyone and called the meeting to order.

II. CITIZEN COMMENT

There were no citizen comments presented at this time.

III. ADMINISTRATION

A. Interim Director of Special Projects and Grants David Coffey gave the following update:

- The Campus project kicked off with construction fencing going up and demo started on February 12. Construction crews will start soon on the structural repairs that are needed under the gym floor. The seats have been removed from the auditorium.
- The Aquatic & Fitness Center renovations are going well. The women's locker room passed inspection. The new hot plunge install is underway. The project is scheduled to complete by end of March.

City Manager Scott Hildebran gave the following funding highlights:

- Google has donated \$100,000 for the Phase 2 of The Campus Project for the Overmountain Victory Trail (OVT) Pavilion.
- Blue Ridge Energy informed the City late last week that the United States Department of Agriculture Rural Economic Development Loan Program has awarded the City loan funding of \$1,180,000 (0% interest, for a 7-year term) to purchase a new 107-foot Ladder Fire Truck. Additional details will be forthcoming on the loan award. Staff has been in contact with our fire truck representative with truck delivery currently taking up to 6 to 18 months. The cost of the ladder truck is approximately \$1,800,000.
- In 2025, the Federal Emergency Management Agency (FEMA) awarded the City a Building Resilient Infrastructure and Communities (BRIC) Grant for the

- Zack's Fork Sewer/Equalization Basin Project; however, FEMA subsequently canceled the program. After 22 states sued FEMA, a federal court in December 2025 ordered reinstatement of the funding. The NC Department of Justice is asking the court to expedite the \$220 million in funding for 70 projects, including \$7.68 million for the Lenoir project, from FEMA.
- Late last week, the North Carolina State Water Infrastructure Authority (SWIA) awarded the City \$3 million in loan funding for the Lenoir/Valdese Water Interconnection Project. The city previously was awarded \$17 million in grant funds for the project.

IV. PUBLIC SAFETY

- A. Police Chief Andy Wilson gave the following update:
- Chief Wilson said the Police Department is collaborating with Western Carolina University's Community Care Program. This program partners graduate students in social work with local police departments. Wilson said this would be a huge benefit to our department, especially in cases where officers are not trained for certain situations. This program is an internship, which could lead to a full-time position. A handout was given to council for reference.

City Manager Scott Hildebran said this would give the police department more support.

City Council were in favor to pursue and move forward with the Community Care Program.

Police Chief Andy Wilson said the former William Lenoir Middle School location will no longer house Horizons Elementary students, they will be dispersed to their home school. The Gateway School located on the Dudley Shoals Road will be closed and relocated at the former William Lenoir Middle School location.

- B. Fire Chief Norman Staines presented the following highlights from the 2025 annual report:
- The department responded to 3,253 calls for service.
 - Staff participated in the North Carolina Smoke Detector Saturday Canvas, installing 36 smoke detectors at no cost to the citizens.
 - Capital Improvement Projects completed were Ranger 1 (Polaris Ranger 1000), four Ventis Pro5 Gas Detectors, two Seek Thermal Imaging Cameras, and three Automated External Defibrillators (AED).
 - The Lenoir Fire Department received the Disaster Relief Grant (H.B. 1012).
 - Many retirements and promotions within the department.
 - Staff documented 16,843.75 hours of training.
 - The fire department conducted 44 classes/presentations to 5,510 citizens and installed a total of 59 smoke detectors.

A copy of the 2025 annual report is attached to these minutes as information.

V. PUBLIC SERVICES

- A. Public Services Public Works Director Jon Hogan gave the following update:
- Lenoir Fire Department Infrastructure Repair (Sinkhole): Project is currently being advertised. A Pre-Bid meeting is scheduled for February 24 at 2 p.m. at Public Services. The bid openings are scheduled for March 5 at 2 p.m.
 - Hospital Avenue Sidewalk Project: Project is underway. The contractor is currently grading. A site meeting is scheduled for February 25 at 10 a.m. to discuss utilities and ADA transitions.
 - Wayfinding Signs Project: Rite Lite Signs and the sub-contractor will begin March 3 with the hydro excavating and the remaining sign footer locations. Sign installations will begin late March.
 - Phase II Gateway Project: Rite Lite Signs has completed staking of the sign locations with a spring/summer installation.
 - Clock Tower: Western North Carolina Sculpture Center is finishing the welding of the art tiles. The city will meet with concrete contractors to discuss foundation work.
 - Greenway Pedestrian Bridge Repair: Bid Award for the Pennell Street Pedestrian Bridge that was damaged during Hurricane Helene will be on the March 3 council agenda.
- B. Public Services Public Utilities Director Jeff Church gave the following update:
- Lenoir-Valdese Water Interconnect: The city received notice on February 17 that we were eligible and will receive an additional \$3 million in State Reserve Program (SRP) loan.
 - Lower Creek WWTP Process Basin Upgrades: The Engineering Report/Environmental Information Document (ER/EID) was submitted to the Division of Water Infrastructure (DWI) on January 15, 2026 and is currently under review.
 - Capital Improvement Projects (CIP)
 - Update and Financial Analysis: The second meeting with city staff is scheduled for March 5.
 - Water and Sewer AIA: Water and sewer evaluations and recommended projects are being completed. High priority projects that would be recommended in years 1-10 will be discussed in the CIP meeting. The Asset Management Plan will be prepared after completion of the assessments and the CIP.
 - Finley Water project: This project is under construction.
 - Sewer Replacements:
 - Division 1: Ridge Street is completed.
 - Division 2 (East Harper) pre-construction meeting was held on February 17 with the Notice to Proceed date of March 2. Progress meetings will be held on the first Thursday of the month at 10 a.m., beginning on April 9.

- Lead and Copper: Project is ongoing and working on the predictive modeling program.

VI. COMMUNITY DEVELOPMENT

A. Economic & Main Street Director Brenda Floyd gave the following update:

- The Lenoir Business Advisory Board met in February. The project on H Lewis Price Street is now complete and also provides an Airbnb downtown.
- The Merchant Mingle will meet in March with the new Downtown District Officer.
- The Paint it Forward Mural Project will start soon. The art is for 13 city owned and maintained traffic signal cabinets.
- The North Carolina Main Street Conference will be held in New Bern, NC, March 10-12.
- A grant application with Duke Energy was submitted for America 250.
- The Bike Fest and Bootlegger 100 events will be held April 18.
- The 2026 Black Berry Festival vendor spots are more than half full.
- Volunteer Meetups begin in March.

B. Planning Director Hannah Williams gave the following report and update:

1. Single-Family permit fee change: The Planning Department fees increased in 2025 making the single-family zoning permits to become costly. The fee is currently calculated by $\$50 + (.10/\text{SF})$ \$1000 max.

Hannah Williams proposed the fee be changed to \$100.00, which includes a driveway permit.

Upon a motion by Councilmember Stevens, City Council voted 7 to 0 to change the Single-Family permit fee to \$100.00, as presented.

2. Planning Department updates:

- Code Enforcement Officer Matt Bolick will begin the Certified Zoning Official course this spring through the UNC School of Government.
- The 7 Brew coffee shop submitted an application at the old Popeyes site location.
- The Mcleod Center for Well Being submitted an application at 348 Harper Ave.
- His Humble Hands has moved the sleeping pods to another location that is in the Extra-Territorial Jurisdiction (ETJ) city limits across from Valmead Elementary School.
 - Hannah Williams said she appreciates all the support on this matter.
- The Planning Board has two rezoning cases in March. A conditional zoning for a 68-unit apartment complex on Sehorn Drive and a rezoning on Ellison Place to allow for a drive thru.
- The Planning Department and Code Enforcement have been evaluating downtown properties to be put under code enforcement for building standards. The property

owners will first receive a warning letter to discuss. A list of downtown properties was provided to council for reference.

C. Parks & Recreation Director Phil Harper reported on the following:

- Please keep Recreation Advisory Board member Charlie Pilkenton in your thoughts upon the passing of his father, Stephen Pilkenton.
- Youth basketball and lap swim are going well. Youth registration for t-ball and softball are ongoing.
- The Aquatic & Fitness Center renovations are going well with a completion date in March.
- Open gym for adult basketball and pickle ball are going well.
- Spring swim begins March 3.
- The Senior Aquatic Specialist position is still open.
- Kathy Dula is the new Administrative Assistant at the Martin Luther King Jr. Center.

VII. FINANCE & ADMINISTRATION

B. Finance Director Donna Bean gave the following update:

1. Resolution; Penny Policy. The City of Lenoir is experiencing a shortage of pennies due to the stopping of minting. In order to keep services running smoothly when a customer is making cash payments, the city will temporarily use symmetric rounding only when pennies are not available to exact change. A credit/debit will be applied towards their next payment.

When rounding is necessary, cash payments will follow these guidelines:

\$0.01 and \$0.02 → rounded down to \$0.00

\$0.03 and \$0.04 → rounded up to \$0.05

\$0.06 and \$0.07 → rounded down to \$0.05

\$0.08 and \$0.09 → rounded up to \$0.10

Upon a motion by Councilmember Prestwood, City Council voted 7 to 0 to approve the Resolution Penny Shortage Policy, as presented.

2. Financial Summary:

The General Fund was within budget and progressing as expected.

A copy of the financial summary is attached to these minutes as information.

C. Communications & Public Information Director Joshua Harris gave the following update:

- Communication Report. There were 6 new releases, 217 social posts, 182 photos, 2 videos, and 91 web updates. The website had a total of 45,374 views along with 4,862 video views. Social followers total 65,452 and there were 1,294 new followers this month.
- The Leadership Lenoir Civic Learning Academy had 27 applications and the first session will be held March 9 at 5:30 p.m. at City Hall, Third Floor.

- The Leprechaun Leap will be held March 14.

VIII. OTHER

- A. January Calendar: The calendar for the month of November was provided in the packet as information.

IX. ADJOURN

There being no further business, the meeting was adjourned at 10:08 a.m.

Attachments

Fire Department 2025 Annual Report

Resolution Penny Shortage Policy

January Financial Summary

CITY OF
LENOIR FIRE
DEPARTMENT

2025 ANNUAL REPORT



OFFICE OF THE CHIEF

It is my honor to be your Fire Chief and present to you the 2025 Annual Report. This report reflects some of the many accomplishments for the Lenoir Fire Department this year. Staff continued to be challenged to explore new industry trends and ways to implement them into our department to improve services.

2025 was another busy year for the department by responding to 3,253 calls for service. This equates to 8.9 calls daily. These calls are answered while staff complete other functions of their job while responding without delay.

I continue to be amazed with the dedication and passion departmental staff have for the City, citizens and businesses for which they protect. They continue to find ways to better themselves and the department which results in a better service to our citizens and businesses.

Yours in public service,

Norman Staines, Fire Chief



2025 ACCOMPLISHMENTS AND HIGHLIGHTS

- Staff participated for the second consecutive year in the North Carolina Smoke Detector Saturday Canvas. Staff were able to install all 36 smoke detectors during the canvas at no cost to the Citizens of Lenoir.
- All staff were fitted to wear respirators to allow them the ability to assist departmental fire investigators during their post-fire investigations to reduce exposure to dangerous carcinogens.





CAPITAL IMPROVEMENT PROJECTS COMPLETED

- Ranger 1 was completed and placed in service in early 2025. It is a Polaris Ranger 1000 that was upfitted with an Enforcer 10 (compressed foam) system that was mounted on a custom box in the bed. The bed also allows for transport of a patient on a stokes basket if needed with an attendee in a seat on the box. *Total cost of this project was \$45,800.59.*
- Federal requirements effective July 1, 2025, have required replacement of twelve of our mobile (truck) radios and upgrades to all our portable radios. Those radios not meeting the "P-25 phase II" compliance will not be operable after June 30, 2025. All equipment purchases and upgrades were completed by the appropriate date. *Total cost of this project was \$61,266.86.*



CAPITAL IMPROVEMENT PROJECTS COMPLETED

- Four new 4 Ventis Pro5 Gas Detectors were purchased. These replaced aging detectors that were too costly to repair and maintain. In addition, this made all multi-gas detectors within the fire department the same to help simplify operations by staff. Total cost of this project was \$7,147.98.
- Two new Seek Thermal Imaging Camera (TICs) were purchased to increase firefighter safety. These cameras replaced older model TICs that lacked new technology and were having operational issues. Total cost of this project was \$10,094.29.
- Three new AEDs were purchased to replace older molder AEDs based on manufacturer recommendations. Total cost of this project was \$8,047.16.



CAPITAL IMPROVEMENT PROJECTS COMPLETED

- To increase firefighter safety on the fireground new scene lights were included in the 2024/25 CIP. This allowed 22 battery operated scene lights to be purchased and placed on each apparatus. These lights are quicker to deploy compared to older lights and are LED lights which are brighter and more energy efficient. Total cost of this project was \$12,560.91.
- Twenty-one station gear lockers were installed at Station 2. This placed lockers at Station 2 similar to other stations. Total cost of this project was \$5,873.39.
- As part of 2025/26 City of Lenoir budget, the replacement of Ladder 1 was approved contingent upon assistance with Blue Ridge Energy in obtaining funds through the government’s Rural Economic Development Loan and Grant program (REDLG). In planning for this purchase equipment to be placed on the new Ladder 1 was purchased. This equipment included a Hurst StrongArm, Hurst Combi Tool, SuperVac PPV Fan and Sthil Rescue Saw, Chainsaw and Cut-off Saw. Total cost of this project was \$30,510.44.



DISASTER RELIEF GRANT (H.B. 1012)

- City of Lenoir Fire Department received a Disaster Relief Grant in the amount of \$50,000 that was to be used to enhance wildland firefighting capabilities. A Polaris Ranger 1000, Enforcer 30 foam suppression system and 25 gallons of Class A/B foam was purchased. The total project cost was \$50,206.15 which resulted in a cost of only \$206.15 to the citizens of Lenoir.



2025 STAFF RETIREMENTS AND PROMOTIONS

Retirements

- Deputy Chief Kenneth Nelson
- Captain Mike Clark
- Captain Thad Dillard
- Captain Tip White

Promotions

- Captain Shane Bowman
- Captain Scott Brawley
- Captain Jamie Greer
- Captain Andrew Lafon
- Lieutenant Matt Frazier
- Lieutenant Matt Price
- Lieutenant Brian Watson
- Engineer Macie Farr
- Engineer Jacob Gilbert
- Engineer Jody Spears
- Engineer Eli Woodie

TEN-YEAR COMPARISON OF CALLS FOR SERVICE

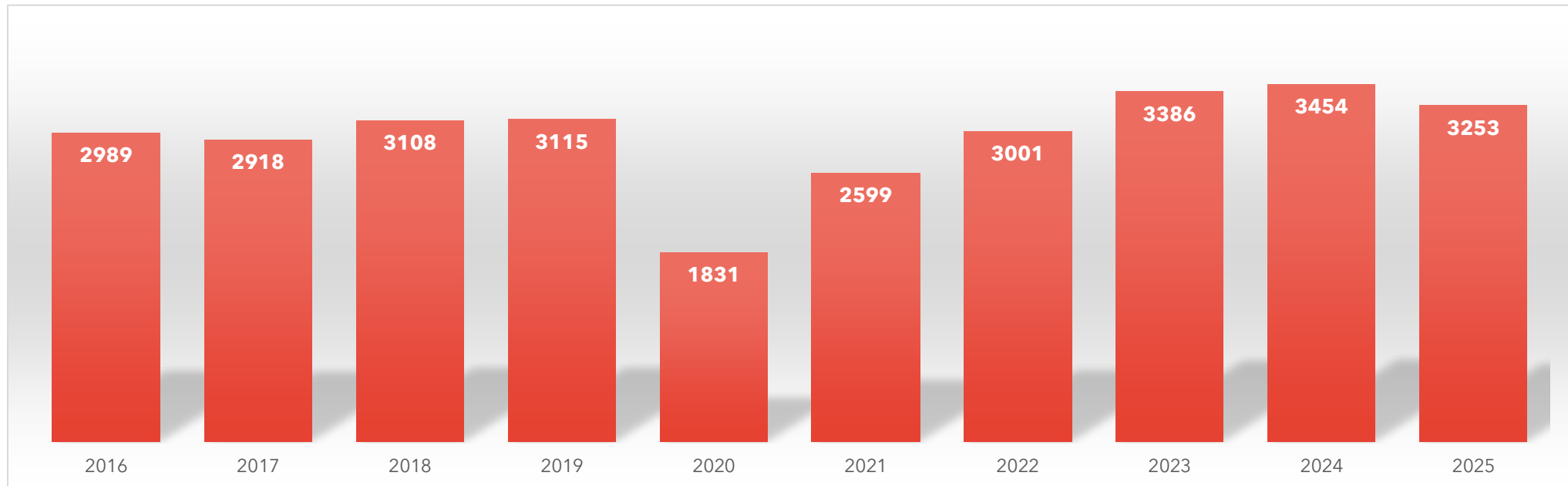

2020 call reduction due to COVID

2024 call inflated due to Hurricane Helene

2025 CALLS PER MONTH

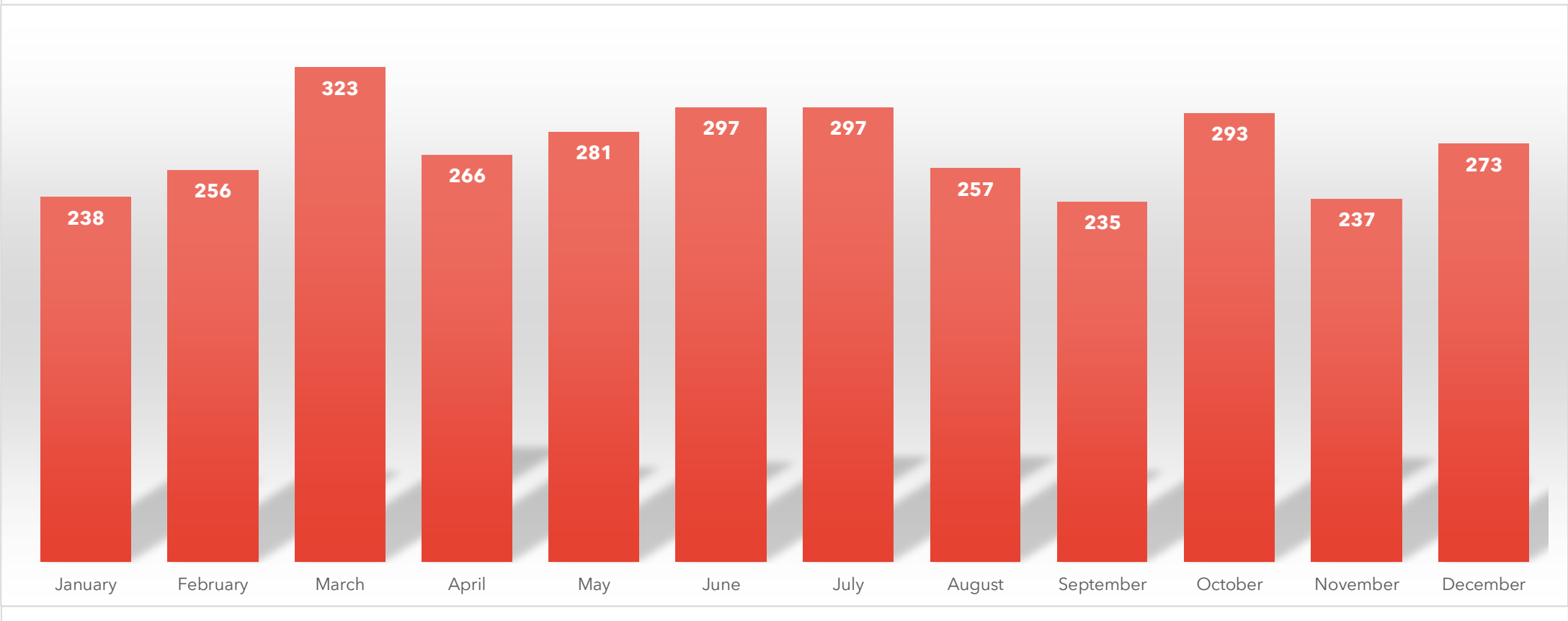

20 YEAR CALL COMPARISON

Year	EMS Calls	Non-EMS Calls	Total Calls For Service
2005	1,297	765	2,062
2010	1,593	1,027	2,620
2015	1,598	1,297	2,895
2019	1,911	1,204	3,115
2020	975	856	1,831
2025	2,166	1,087	3,253

RESPONSES BY DISTRICT

District	Responses	Percentage of Total Calls
Station 1	1,802	55.4%
Station 2	772	23.7%
Station 3	679	20.9%
TOTAL CALLS FOR SERVICE	3,253	100%



LOCATIONS WITH MULTIPLE INCIDENTS

Address	Facility Name	# Incidents
318 NW North Main Street	Koinonia	49
100 NW Abington Road	Arbor Glen	42
102 SW Willow Street	LHS Apartments	36
322 NE Nuway Circle	Lenoir Healthcare	34
515 NW Scroggs Street	Shelter Home of the Foothills	26
1350 SE Panther Trail	Hibriten High School	26
506 NE Lower Creek Drive	Skyland Apartments	25
2303 SW Walt Arney Road	Walt Arney Estates	23
431 NW Vance Street	Lenoir Housing Authority	23
2345 SW Morganton Boulevard	Caldwell County HHS Building	22



SUPPRESSION REPORT

TYPES	2022	2023	2024	2025
FIRE				
Building fires	43	35	28	39
Vehicle fires	20	20	23	18
Brush or grass fires	22	28	24	25
Trash or dumpster fires	16	16	25	24
Other fires	6	4	22	14
Potential fires	30	48	79	88
Explosion	0	0	1	1
TOTAL FIRE CALLS	137	151	202	209
FALSE ALARMS				
Cancelled	82	98	105	119
Malicious	4	8	3	4
Malfunction	97	88	67	65
Unintentional	252	278	197	211
Carbon Monoxide	8	7	25	10
TOTAL SUPPRESSION CALLS	443	479	397	409

EMS CALLS

TYPES	2022	2023	2024	2025
Medical Calls	1,517	1,828	1,826	1,778
EMS Lift Assistance	72	87	87	94
Assist Invalid	29	49	71	56
Motor Vehicle Accident - Personal Injury	119	138	135	135
Motor Vehicle Accident - No Personal Injury	119	104	107	103
TOTAL MEDICAL CALLS	1,857	2,206	2,226	2,219



MISCELLANEOUS CALLS

TYPES	2022	2023	2024	2025
Hazardous Condition / Material Spills or Leaks	71	78	117	65
Public Service Calls	259	209	128	153
Rescue Calls	31	44	79	48
Rescue Stand-by	98	77	13	87
Cover Assignment / Stand-by	10	3	2	25
Burning legal / illegal	66	89	49	68
Severe Weather Calls	29	50	172	23
TOTAL MISCELLANEOUS CALLS	564	550	629	469
TOTALS CALLS FOR SERVICE - ALL CALLS	3,001	3,386	3,454	3,253

AVERAGE RESPONSE TIME

	2022	2023	2024	2025
Station 1	3:43	3:37	3:07	3:00
Station 2	3:47	3:42	3:12	3:16
Station 3	3:45	3:11	3:17	3:14
Average Response Time - All Calls - All Stations	4:04	3:39	3:12	2:59





2025 ANNUAL TRAINING

- Staff documented 16,843.75 hours of training in 2025.
- These hours are comprised of various topics to include EMT, fire, rescue, officer / leadership, hazardous materials and drivers training.

TEN-YEAR COMPARISON ON TOTAL TRAINING HOURS

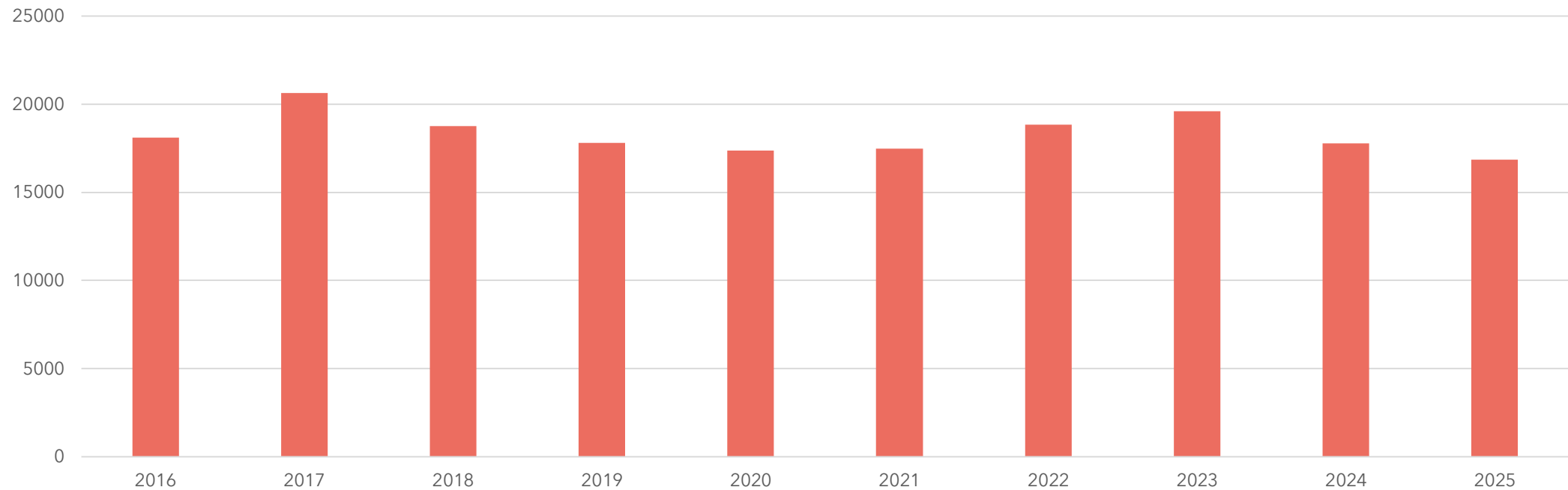

*To increase annual training, in January 2026 a 6 to 8 hours monthly online training program was started. In February 2026 staff will start participating in 18 to 24 hours of facilities off-duty training annually.

TRAINING & SPECIAL CLASSES ATTENDED

- N.C. Fire Prevention School: One Firefighter attended
- NC/SC IAAI Conference: Three Firefighters attended
- N.C. State Fire Conference: Two Firefighters attended
- N.C. Breathing Equipment School: Two Firefighters completed the school
- NCOSFM Fundamentals of Fire Investigations: Two Firefighters completed the course
- N.C. Driver Operator Aerials Class: Twelve Firefighters completed the certification
- TR Trench: Twelve Firefighters completed the certification
- Fire Life Safety Educator II: Four Firefighters completed the certification
- Fire Life Safety Educator III: Two Firefighters completed the certification



FIRE PREVENTION AND EDUCATION

- In 2025, Lenoir Fire Department conduct 44 classes / presentation to 5,510 citizens.
- In 2025, Lenoir Fire Department installed a total of 59 smoke detectors.
- On June 7, 2025, Lenoir Fire Department participated for the second time in the North Carolina Smoke Detector Canvas and were able to install all 36 smoke detectors in a single Saturday.



COMMUNITY INVOLVEMENT

- We had seventeen staff members participate in the City's "Litter Sweep" event in Spring and fourteen in the Fall.
- Staff participated in multiple events within the City of Lenoir. These events include the Blackberry Festival, July 4th Fireworks, Light Up Lenoir, Luminaries, Lenoir Christmas Parade, Turkey Tuesday, Downtown Halloween Spooktackler and the MLK Center Trunk-or-Treat.
- Staff assisted with traffic control during the funeral procession for Andy Day, retired Police Chief for the Town of Hudson.
- Staff participated in several local summer camps. These included the Keith Owens Firefighter Academy at Gamewell Fire Department and the summer reading and enrichment program at New Covenant UMC.
- Staff participated in career fairs at Caldwell Early College, Hibriten High School and West Caldwell High School.



FIRE PREVENTION AND INSPECTIONS

Inspections	2022	2023	2024	2025
Occupancy Group - A (Assembly)				
A-1 Assembly with fixed setting for performing arts or motion picture	2	9	10	5
A-2 Assembly uses intended for food and drink consumption	64	95	126	104
A-3 Assembly uses intended for worship	36	167	73	37
A-4 Assembly uses intended for viewing indoor sporting events and activities	1	2	6	5
A-5 Assembly uses intended for viewing outdoor activities (bleachers, stadiums, etc.)	11	9	11	17
Occupancy Group - B (Business)				
B	209	592	300	181
Occupancy Group - E (Education)				
E	43	67	60	50



FIRE PREVENTION & INSPECTIONS (CONT.)

Inspections (Cont.)	2022	2023	2024	2025
Occupancy Group F (Factory / Industrial)				
F-1 Moderate-Hazard Factory Industrial	46	67	100	109
F-2 Low-Hazard Factory Industrial	14	7	1	0
Occupancy Group H (High-Hazard)				
H-1 High-Hazard Group	1	3	1	0
H-3 High-Hazard Group	7	3	2	3
Occupancy Group I (Institutional)				
I-2 Structures used for medical, nursing or custodial care on a 24 hour basis	15	14	36	34
I-3 Building and structures which are inhabited by 5 or more under restraints	2	2	1	3
Occupancy Group M (Mercantile)	72	136	122	110



FIRE PREVENTION & INSPECTIONS (CONT.)

Inspections (Cont.)	2022	2023	2024	2025
Occupancy Group R (Residential)				
R-1 Boarding house or hotel	13	26	20	5
R-2 Apartment houses	52	139	146	157
R-3 Other residential	5	18	13	4
R-4 Assisted living facilities	6	6	12	18
Residential Special - (Foster Homes)	12	9	8	11
Occupancy Group U (Tents)	1	3	2	0
S-1 Storage Group	14	37	33	0
S-2 Storage	2	12	7	4
Total Inspections	638	1,417	1,090	875



2025 FIRE LOSS VS. SAVE REPORT

Property/Contents Pre-fire Value	Property/Contents Loss	Total Value Saved
\$43,213,800	\$2,180,100	\$41,033,700

53 Incidents with Property Loss with 92.90% of Property Value Saved
29 Incidents with Content Loss with 83.62% of Content Value Saved







CITY MANAGER
SCOTT E. HILDEBRAN



CITY OF LENOIR
NORTH CAROLINA

RESOLUTION

MAYOR
Joseph L. Gibbons

CITY COUNCIL
J.T. BEAL
R.C. DELLINGER
J.I. PERKINS
R. PRESTWOOD
K.R. ROGERS
D.F. STEVENS
C.D. THOMAS

RESOLUTION PENNY SHORTAGE POLICY

WHEREAS, The City of Lenoir is experiencing a shortage of pennies due to the stoppage of minting on November 12, 2025 by the U.S. Mint. In response to this shortage, the City of Lenoir will temporarily use symmetric rounding only when pennies are not available for exact change for customers who make cash payments and do not have the exact change. Customers paying with a bank draft, check, money order or with a credit card will not be impacted.

WHEREAS, The City of Lenoir will apply under or overpayments for utility bills to the next month's bill;

WHEREAS, G.S. 105-357(c) authorizes the governing body of a municipality to adopt a resolution permitting its Tax Collector to treat small underpayments of taxes as fully paid and to not refund small overpayments of taxes unless the taxpayer requests a refund before the end of the fiscal year in which the small overpayment is made. The City of Lenoir adopted this resolution on May 2, 2017; and

WHEREAS, the City of Lenoir City Council desires to adopt a resolution regarding penny shortage rounding;

NOW, THEREFORE, BE IT RESOLVED, by the City Council of the City of Lenoir, that the Revenue Collector will use symmetric round only when pennies are unavailable for exact change for those customers paying with cash.

BE IT FURTHER RESOLVED, by the City Council of the City of Lenoir, that the Revenue Collector, will apply under or over payments to customers' utility accounts and pursuant to G.S. 105-357(c), is permitted to treat small underpayments of taxes as fully paid and to not refund small overpayments of taxes unless the taxpayer requests a refund before the end of the fiscal year in which the small overpayment is made.

BE IT FURTHER RESOLVED, that the Tax Collector shall keep records of all underpayments and overpayments of taxes by receipt number and amount and shall report these payments to the City Council at the time of settlement as required by the North Carolina Machinery Act.

BE IT FURTHER RESOLVED, that this resolution shall be effective immediately upon adoption and shall continue in effect unless amended or repealed by resolution of the City of Lenoir City Council.

Adopted this the 24th day of February, 2026.

SEAL

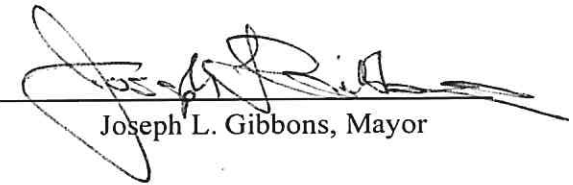



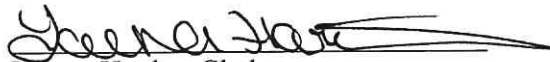

Joseph L. Gibbons, Mayor

ATTEST:



Lauren Hartley, Clerk

 <div style="text-align: center;"> City of Lenoir Financial Summary As of 1/31/2026 </div> 					
General Fund					
	2025-2026 Budget	1/31/2026	% of Budget	Change from Previous Year	1/31/2025
Total Revenue	\$ 25,241,845.00	\$ 18,839,465.94	75%	\$ 1,619,303.80	\$ 17,220,162.14
Expenditures	\$ 25,241,845.00	\$ 14,279,268.46	57%	\$ 1,165,077.74	\$ 13,114,190.72
Over/Under	\$ -	\$ 4,560,197.48		\$ 454,226.06	\$ 4,105,971.42
Downtown District					
	2025-2026 Budget	1/31/2026	% of Budget	Change from Previous Year	1/31/2025
Revenues	\$ 271,550.00	\$ 40,255.41	15%	\$ (483.96)	\$ 40,739.37
Expenditures	\$ 271,550.00	\$ 180,473.97	66%	\$ (10,671.71)	\$ 191,145.68
Over/Under	\$ -	\$ (140,218.56)		\$ 10,187.75	\$ (150,406.31)
Water/Sewer Fund					
	2025-2026 Budget	1/31/2026	% of Budget	Change from Previous Year	1/31/2025
Revenues	\$ 11,963,721.00	\$ 7,412,342.59	62%	\$ 437,503.13	\$ 6,974,839.46
Expenditures	\$ 11,963,721.00	\$ 6,225,301.47	52%	\$ 591,326.35	\$ 5,633,975.12
Over/Under	\$ -	\$ 1,187,041.12		\$ (153,823.22)	\$ 1,340,864.34

		City of Lenoir Financial Summary By Department As of 1/31/2026			
General Fund					
	BUDGET	1/31/2026	% OF BUDGET		
REVENUE					
PROPERTY TAXES	\$ 11,051,130.00	\$ 11,191,208.78	101%		
SALES TAX	\$ 6,341,600.00	\$ 2,918,307.46	46%		
FRANCHISE TAX	\$ 2,410,000.00	\$ 1,237,007.74	51%		
SOLID WASTE FEE	\$ 1,111,000.00	\$ 657,003.36	59%		
OTHER	\$ 4,328,115.00	\$ 2,835,938.60	66%		
TOTAL	\$ 25,241,845.00	\$ 18,839,465.94	75%		
EXPENDITURES					
LEGISLATIVE	\$ 417,895.00	\$ 175,846.74	42%		
ADMINISTRATIVE	\$ 978,543.00	\$ 558,807.00	57%		
FINANCE	\$ 1,045,766.00	\$ 477,889.44	46%		
PLANNING	\$ 571,876.00	\$ 360,785.50	63%		
POLICE	\$ 8,092,222.00	\$ 4,988,372.23	62%		
FIRE	\$ 6,265,816.00	\$ 3,140,222.61	50%		
RECREATION	\$ 1,700,504.00	\$ 1,005,631.34	59%		
PUBLIC WORKS					
Administrative	\$ 301,040.00	\$ 250,779.39	83%		
Cemetery & Grounds	\$ 1,242,833.00	\$ 866,655.35	70%		
Building Maintenance	\$ 461,039.00	\$ 273,373.39	59%		
Sanitation	\$ 1,531,540.00	\$ 960,670.73	63%		
Streets	\$ 2,281,934.00	\$ 1,035,455.49	45%		
Vehicle Services	\$ 350,837.00	\$ 184,779.25	53%		
TOTAL	\$ 25,241,845.00	\$ 14,279,268.46	57%		
OVER/UNDER	-	\$ 4,560,197.48			
Downtown District					
	BUDGET	1/31/2026	% OF BUDGET		
TOTAL REVENUES	\$ 271,550.00	\$ 40,255.41	15%		
TOTAL EXPENDITURE	\$ 271,550.00	\$ 180,473.97	66%		
OVER/UNDER	-	\$ (140,218.56)			
Water/Sewer Fund					
	BUDGET	1/31/2026	% OF BUDGET		
REVENUE					
WATER SALES	\$ 7,500,043.00	\$ 4,574,661.91	61%		
SEWER SALES	\$ 3,694,678.00	\$ 2,378,005.19	64%		
CAPITAL RESERVE	\$ 1,300,000.00				
OTHER	\$ 769,000.00	\$ 459,675.49	60%		
TOTAL REVENUES	\$ 13,263,721.00	\$ 7,412,342.59	56%		
EXPENDITURES					
ADMIN & ENGINEERING	\$ 563,036.00	\$ 296,559.18	53%		
WATER RESOURCES	\$ 446,702.00	\$ 271,725.88	61%		
RHODISS PLANT	\$ 2,717,859.00	\$ 1,226,062.91	45%		
WATER DISTRIBUTION	\$ 2,942,820.00	\$ 1,388,897.42	47%		
WASTEWATER COLLECTION	\$ 3,126,772.00	\$ 1,386,463.12	44%		
WASTEWATER PRETREATMENT	\$ 197,139.00	\$ 111,800.92	57%		
GUNPOWDER WASTEWATER PL	\$ 899,194.00	\$ 412,936.51	46%		
LOWER CREEK WASTEWATER PL	\$ 2,370,199.00	\$ 1,130,855.53	48%		
TOTAL EXPENDITURE	\$ 13,263,721.00	\$ 6,225,301.47	47%		
OVER/UNDER	\$ -	\$ 1,187,041.12			

**CITY OF LENOIR
COUNCIL ACTION FORM**

- I. Agenda Item:** Bid Award: Pennell Street Greenway Pedestrian Bridge Repair; Staff recommends awarding the contract to Shotcrete Contractors Inc. for the lump sum of \$ 59,700.00. Shotcrete Contractors Inc. is the lowest, responsive, responsible bidder, is appropriately licensed and is adequately equipped to perform work of this nature.
- II. Background Information:** In December of 2024, while conducting a post Hurricane Helene asset evaluation, staff noticed that the greenway pedestrian bridge that connects the Powell Road section of greenway to the Joan Rogers Trail section had suffered significant washout and scouring around the concrete footer (west end) that supports the pedestrian bridge. Due to the hurricane damage, the bridge was included in our FEMA Damage Inventory. Upon investigation, it was determined the bridge could be repaired in place versus full replacement. The initial estimate for the repair was \$53,658.00. After a FEMA site inspection (attached), the project was elevated for reimbursement consideration. In addition, the NC State Historic Preservation Office (SHPO) made a determination that the bridge held no historical significance and funding consideration could proceed. Earlier this year, FEMA approved the project for reimbursement at the initial estimated cost of \$53,658.00, and the NC Department of Public Safety awarded funding this month.

The City received the following informal bids for the bridge repair:

1. Shotcrete Contractors Inc.	BID \$ 59,700.00
2. Performance Shotcrete	BID \$ 65,000.00
3. CH Barlowe LLC.	NO BID

The City will cover the difference in estimated cost and actual cost, in the amount of \$6,132.00.

- III. Staff Recommendation:** Following review of bids obtained for this bridge repair, staff recommends awarding the contract to Shotcrete Contractors Inc. for the lump sum of \$ 59,700.00. Shotcrete Contractors Inc. is the lowest, responsive, responsible bidder, is appropriately licensed and is adequately equipped to perform work of this nature.

IV. Reviewed by:

City Attorney: _____

Finance Director:

Public Works/Public Utilities Director: JH

January 28, 2026

City of Lenoir
Public Works Depart.
510 Greer Circle SW#B
City of Lenoir, NC 28645

Subject: Proposal for Greenway Pedestrian Bridge Repair

Dear Mr. Hogan,

Shotcrete Contractors is pleased to offer this Proposal for the above-referenced project. This proposal is exclusively for City of Lenoir Public Works herein known as the "Owner," to consider. The site is located at 415 Pennell St NE, Lenoir, NC.

I. Proposed Scope of Work

Perform necessary repairs to stabilize existing abutment located under the West end of the bridge, including scour protection.



Figure 1: View at existing bridge



Figure 2 & 3: View at abutment requiring scour protection

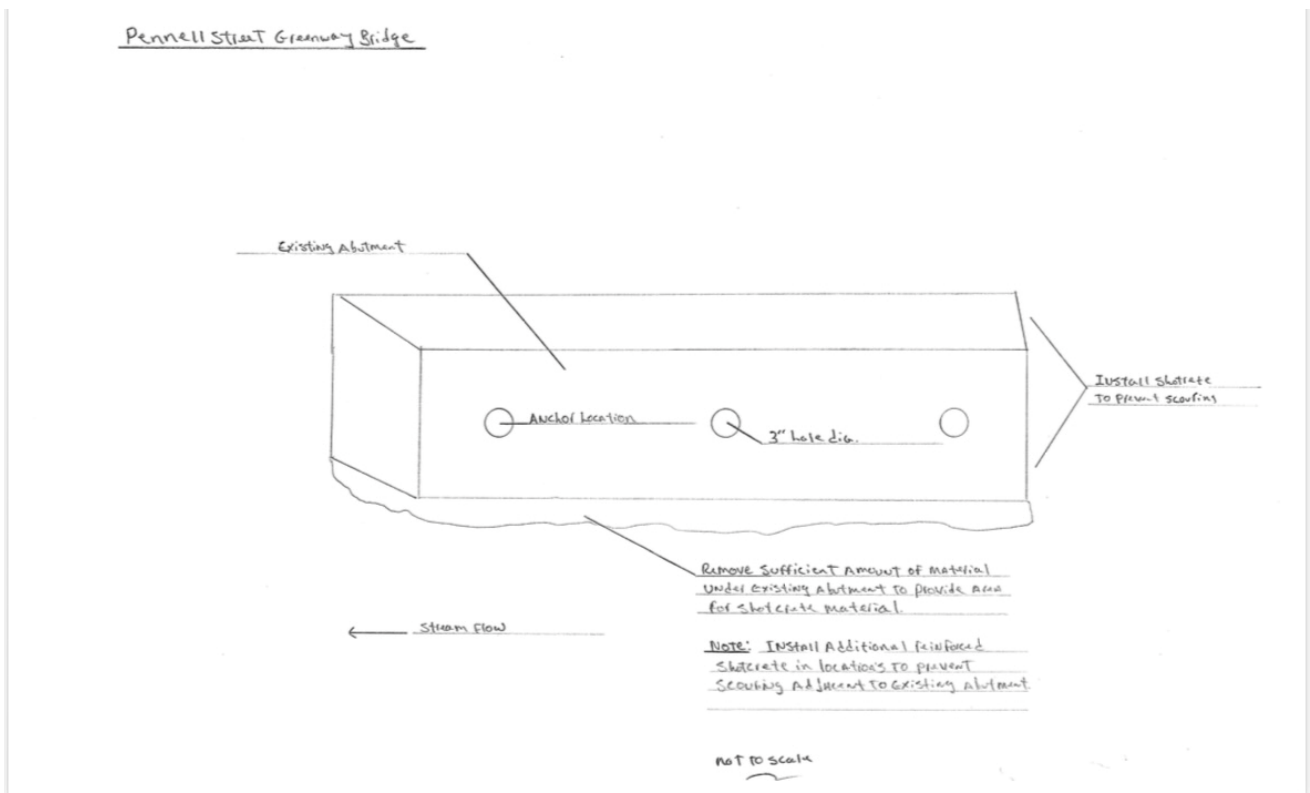

Figure 4: Proposed repair with anchor locations determined in the field

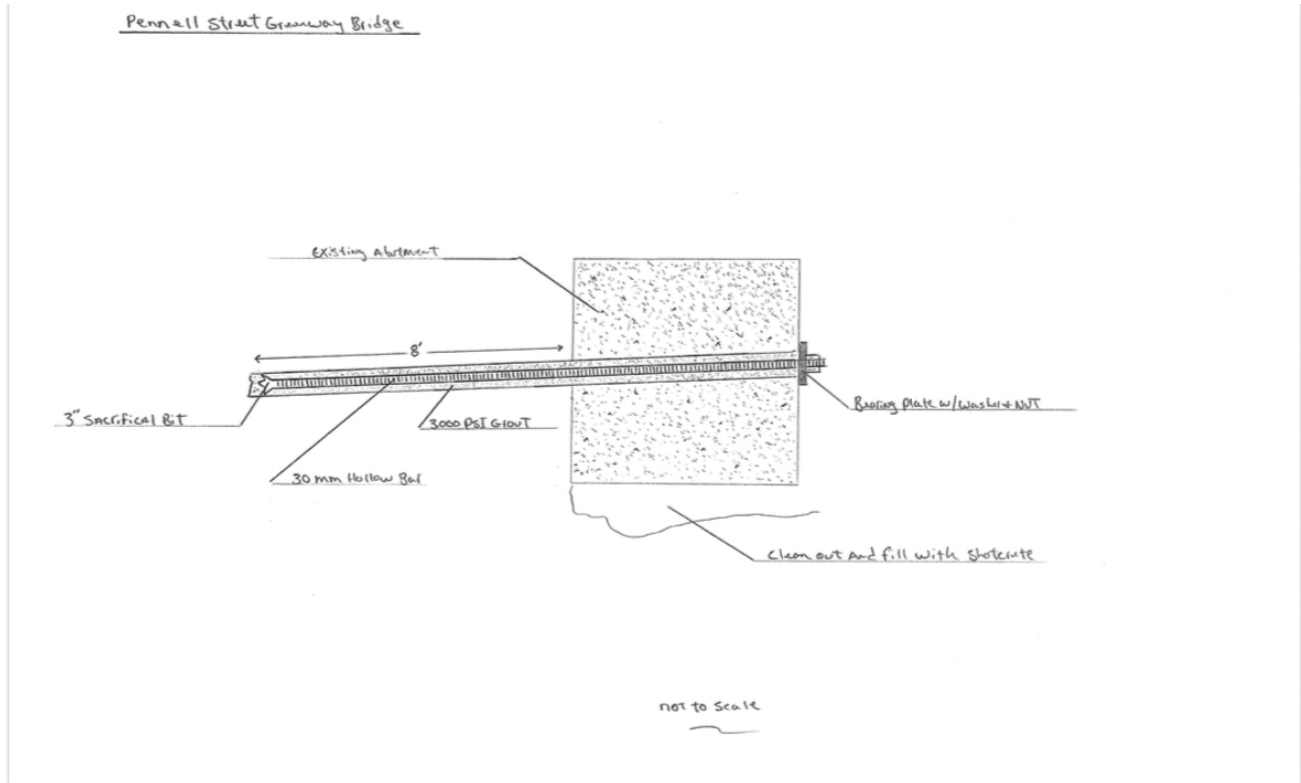

Figure 4: Proposed repair with anchor locations determined in the field

II. Roles and Responsibilities

Shotcrete Contractors' scope of work includes labor, tools, equipment, and materials to design and install anchors to secure abutment and install shotcrete under abutment and adjacent areas to prevent scouring. Please see detailed drawings.

1. Once mobilization is completed all vegetation will be cleaned away adjacent to the abutment. Additional dirt and debris will be removed from under the abutment to provide for shotcrete application.
2. Once abutment is secured with shotcrete holes will be cored through the abutment and anchors installed per detailed drawing.

Owner would be responsible for the following:

1. Continuous access to the work area (five days per week, up to 10 hours per day).
2. Access to potable water.
3. Provide access for SCI equipment on-site.

III. Key Assumptions, Clarifications and Exclusions

The following are additional key assumptions made in the preparation of this proposed scope and

fee.

- No off-site waste is assumed.
- No surveying is included (e.g. layout survey, as-built survey, and wall tolerances as required).
- The cost of a bond premium is not included in the Shotcrete Contractors' price. If desired by and paid by the Owner, Shotcrete Contractors will furnish a Payment and Performance Bond at a rate of 2% of the total price.
- Prevailing wages are not included in Shotcrete Contractors' price.
- Buy American/American Material Requirements are not included in Shotcrete Contractors' price.
- Quote does not include the removal or relocation of any utilities.
- No design engineering or permitting is included.
- Work assumes favorable weather and site readiness.
- Shotcrete will be applied in strict accordance with ACI Specifications governing Shotcrete Application. All work will be performed with personnel frequently engaged in the application of shotcrete.
- Work assumes favorable weather and site readiness.

IV. Anticipated Schedule

Shotcrete Contractors estimates that the work described above can be completed in approximately **8 days**. The approximate delivery schedule below assumes timely delivery of information and review comments from the owner. All construction work is based on a work schedule of Monday through Friday, up to 10 hours per day as weather and daylight permits. Shotcrete Contractors can mobilize to the site within a mutually negotiated timeframe from Shotcrete Contractors receiving an executed contract, approved submittals, and a written notice to proceed.

V. Pricing

Our scope of work includes labor, tools, and equipment to perform the work described herein based on the prices listed below. The prices included herein are based and expressly conditioned on continuous unobstructed work beginning the day Shotcrete Contractors mobilizes on the site. Should the work not proceed as continuous unobstructed work, the price to perform the work may likely increase. We propose to perform the above scope of work via the following fee breakdown. This pricing also assumes work is completed within 10 or more hours of daylight.

Table 1 – Cost Estimate

Item	Description	Qty	Unit	Unit Price	Total
1	Mobilization	1	LS	\$6,000.00	\$6,000.00
2	Install Shotcrete and Anchors	1	LS	\$53,700.00	\$53,700.00
Total					59,700.00

VI. Closure

Thank you for the opportunity to propose this very important project. If you have any questions or would like any additional information, please don't hesitate to contact me.

Sincerely,

Shotcrete Contractors

Mike Milton

Mike Milton

mike.milton@geospecialties.com

c: 423.494.0945

Accepted by: _____
(Signature)

Accepted by: _____
(Printed name/title)

Date: _____

Attachment A – Standard Terms and Conditions

1. Standard of Care

Shotcrete Contractors will perform its services in a manner consistent with the level of care and skill ordinarily exercised by professionals practicing under similar conditions in the same geographic area. These services are subject to the time, budgetary, and physical constraints applicable to the project. No express or implied warranties are provided under this Agreement.

2. Invoices and Payment Terms

Shotcrete Contractors will submit monthly progress invoices and a final invoice upon completion of services. Payment is due upon receipt. Any unpaid balance will be considered past due after thirty (30) days from the invoice date. A finance charge of two percent (2%) per month, or the maximum rate allowed by law, will apply to all past due amounts. The Client agrees to pay any and all attorneys' fees, legal costs, and other collection expenses incurred by Shotcrete Contractors in recovering overdue payments.

3. Delays and Force Majeure

Shotcrete Contractors shall not be held liable for damages or delays in performance resulting from causes beyond its reasonable control. Such causes may include, but are not limited to, actions or inactions by the Client or its representatives, delays by governmental authorities, labor unrest, natural disasters, acts of terrorism, internet outages, supply interruptions, or other events that are unforeseen or not reasonably preventable.

4. Limitation of Liability

The Client must notify Shotcrete Contractors in writing of any actual or suspected deficiencies arising from Shotcrete Contractors' services. Failure to provide such notice will relieve Shotcrete Contractors of any further responsibility. To the extent permitted by law, all liability arising from Shotcrete Contractors' work shall expire no later than one (1) year from the date of the error, act, or omission, or by the applicable statute of limitations—whichever is earlier. In no event shall Shotcrete Contractors' liability exceed the total fee received for the services performed. The Client also acknowledges the inherent limitations of engineering evaluations of subsurface conditions, which may not reflect unknown site conditions or changes over time. Shotcrete Contractors shall not be liable for damages arising from such unknown or changed conditions.

5. Insurance

Shotcrete Contractors maintains professional liability insurance and will provide a certificate of insurance upon request. Shotcrete Contractors' liability is limited to the terms, exclusions, and coverage amounts stated in its insurance policy. Should the Client require additional project-specific coverage beyond existing limits, Shotcrete Contractors will obtain such insurance at the Client's expense, based on the premium differential.

6. Professional Work Product

All reports, plans, field notes, laboratory data, drawings, and electronic media created by Shotcrete Contractors are considered its professional work product and remain the sole property of Shotcrete Contractors. These documents are intended for one-time use on the specific project for which they were prepared and may not be reused on any other project without prior written consent. Unauthorized reuse shall be at the Client's risk, and the Client agrees to defend, indemnify, and hold Shotcrete Contractors harmless from any liability or damages arising from such reuse.

7. Data and Information

The Client shall provide all relevant project information, including reports, studies, plans, specifications, and other documentation necessary for the execution of services. Shotcrete Contractors is entitled to rely on the accuracy and completeness of the information provided and assumes no responsibility for verifying or supplementing that data.

8. Right of Entry

The Client shall provide right of entry for Shotcrete Contractors, its subcontractors, and equipment as needed to perform the contracted services. If the Client is not the property owner, it is the Client's responsibility to secure the appropriate permissions. The Client acknowledges that some surface damage may result from normal activities and that such restoration is not included in Shotcrete Contractors' scope unless specifically noted.

9. Control of Work and Jobsite Safety

Shotcrete Contractors is responsible only for the safety of its own employees and subcontractors. Jobsite safety for all other personnel, contractors, and visitors remains the responsibility of the Client and other consultants. Shotcrete Contractors

does not supervise or control safety conditions at the jobsite and shall not be held liable for any jobsite incidents or injuries beyond its own personnel.

10. Disputes

Any disputes, claims, or controversies arising out of or related to this Agreement shall first be submitted to mediation prior to initiating litigation or arbitration. The parties agree to make a good faith effort to resolve issues through this non-binding process.

11. Termination

This Agreement may be terminated by either party for material breach, provided the breaching party fails to begin and continue corrective actions within seven (7) days of receiving written notice. Upon termination, Shotcrete Contractors shall be paid for all services rendered through the termination date, along with any reimbursable costs, including those related to subcontractors, consultants, materials, and travel. Shotcrete Contractors shall not be held liable for delays caused by suspension of services, and Client payment shall not be withheld based on project financing or third-party reimbursements.

12. Electronic Media

Electronic versions of documents provided by Shotcrete Contractors are subject to inadvertent alteration, degradation, or corruption due to software or transmission errors. These files are submitted for informational purposes only and are valid for review and acceptance for a period of thirty (30) days. Any defects must be promptly reported. Shotcrete Contractors makes no warranties regarding the fitness of such media. Unauthorized reuse, modification, or adaptation of these documents is prohibited, and the Client assumes all risk and liability for doing so.

13. Hazardous Materials and Contaminants

This Agreement does not include the assessment, identification, or remediation of hazardous substances such as asbestos, oil, or radioactive materials. Shotcrete Contractors is not responsible for designing or implementing systems to manage, remove, or treat such contaminants.

14. Miscellaneous Terms

This Agreement supersedes all prior agreements and contains the full understanding between the parties. Any amendment must be in writing and signed by both parties. Neither party may assign this Agreement without the other's consent, and no third-party beneficiaries are created. Shotcrete Contractors may engage affiliated or independent subconsultants, for whose work Shotcrete Contractors remains responsible under the limitations of liability stated herein. No waiver of any provision shall be deemed a waiver of future rights, and all rights and obligations (including those related to liability) shall survive termination.

The Client agrees not to use Shotcrete Contractors' name or any references to its work in public-facing materials without express written consent. If any provision is found unenforceable, the remainder shall remain in effect. This Agreement is governed by the laws of the Commonwealth of Kentucky unless another jurisdiction is required for enforcement. The individual signing on behalf of the Client warrants full authority to bind the Client to this Agreement.

15. Additional Conditions

If site readiness or project delays beyond Shotcrete Contractors' control cause lost time after crew mobilization, the Client agrees to pay a fee of \$600 per crew-hour. Any retainage held shall be released to Shotcrete Contractors within thirty (30) days of its work completion. Shotcrete Contractors shall not be held responsible for liquidated damages, delay damages, or other schedule-related penalties outside its control.

Shotcrete Contractors assumes no liability for disturbances caused by construction vibrations, ground movement, settlement, or unmarked utilities. The Client or Contractor shall indemnify Shotcrete Contractors for any resulting claims and take appropriate precautions, including vibration monitoring or other mitigation. Furthermore, the Client is responsible for ensuring utilities are located prior to mobilization; potholing, relocation, or removal of utilities is not included.

This proposal shall remain valid for **thirty (30) days** from the date of transmittal.

16. Changes and Site Readiness

If the contract scope is modified after Shotcrete Contractors has delivered materials or commenced work, or if the project site is not ready for Shotcrete Contractors to begin work as scheduled, or if other delays occur that are outside the control of Shotcrete Contractors (including but not limited to coordination issues, third-party delays, or site inaccessibility), the Client agrees to compensate Shotcrete Contractors at a rate of **\$600.00 per crew-hour** for lost time. This charge shall apply to each hour a mobilized crew is unable to perform work due to such circumstances.

SITE INSPECTION REPORT

CATEGORY G – PARKS, RECREATION, CEMETERY, OTHER

Applicant Lenoir, City of	PA ID # 027-37760-00	Applicant Representative <i>Jonathan Hogan</i>	Applicant Representative Title <i>Public Works Director</i>
Site Inspection Date 6/11/2025		Site Inspector Name Mike Lee & Marilyn Davis	
Work Order # 110414		Damage # 1508601	
Facility: <input checked="" type="checkbox"/> Park <input type="checkbox"/> Cemetery <input type="checkbox"/> Athletic Field <input type="checkbox"/> Marina <input checked="" type="checkbox"/> Other (Specify): Pedestrian Bridge			
GPS Latitude 35.925333		GPS Longitude -81.519917	
Physical Location (Address of Damage Site) Opposite corner from Greenway Presbyterian Church: 415 Pennell St. NE, Lenoir, NC 28645	Date Damaged 09/28/2024	Age of Facility <input type="checkbox"/> Exact <input checked="" type="checkbox"/> Approximate Year Built: <i>2005</i>	Legal Responsibility <input checked="" type="checkbox"/> Yes <input type="checkbox"/> No

Facility Description: (Pre-disaster design, function, capacity, dimensions, and footprint)
Facility Description Only

Greenway Pedestrian Bridge is part of Lenoir Greenway path/trails for outdoor activities, including running, walking, cycling, and mountain biking. This single-simple-span pedestrian bridge spans over Zacks Fork Creek.

L = 35'-4" (Field Measured Bk Abut to Bk Abut = 41'-8")

W (out to out) = 7'-6"

W (Rail to Rail) = 6'-10"

East Abut #2: W (Curb inside to curb inside) = 81"

99" L } Field Measurement

40" W } 2'-6" Height from the Bridge Inspection Report (Too steep slope to measure)

West Abut #1: 99" L } Field Measurement

30" ~~40"~~ W } 2'-6" Height from the Bridge Inspection Report (Too steep slope to measure).

Clearance: Bottom of Deck Board to Stream Bed = 8'-6"

500"
500
-30
-40

430" face to face Abt
35'-10"

Applicant Representative Signature: *Jonathan Hogan*

Recipient Authorized Representative Signature (if applicable): _____

Facility Component Damages

Site #	Damage Component Material/Model/Type/Capacity	Location Address/GPS/begin-end	Damage Dimensions: (L x W x D/L x Dia) Electrical/Mechanical/etc.
Abt. #001	Side Slope Erosion Unclassified earthen	35.925333, -81.519917	24' L x ($\frac{8' H \times 4' W}{2}$) = 384 cu ft $\frac{384}{27} = 14.22$ cu yd
Method of Repair (change in design, materials, size, capacity etc.)			Cause of Damage ①, ②, High velocity surface runoff
Mitigation would include armoring (ie shotcrete along the eroded slope) See sketch provided by the Applicant in GM.			FA <input type="checkbox"/> Quantity 14.22 ✓ CTR <input checked="" type="checkbox"/> Units cu yd Both <input type="checkbox"/> % Complete 0
Site #	Damage Component Material/Model/Type/Capacity	Location Address/GPS/begin-end	Damage Dimensions: (L x W x D/L x Dia) Electrical/Mechanical/etc.
Abt. #002	" "	" "	24' L x 9' W x 2' D Avg = 432 cu ft / 27 = 16 cu yd
Method of Repair (change in design, materials, size, capacity etc.)			Cause of Damage " "
" "			FA <input type="checkbox"/> Quantity 16 ✓ CTR <input checked="" type="checkbox"/> Units cu yd Both <input type="checkbox"/> % Complete 0
Site #	Damage Component Material/Model/Type/Capacity	Location Address/GPS/begin-end	Damage Dimensions: (L x W x D/L x Dia) Electrical/Mechanical/etc.
Entire Bridge #003	Debris between beams	" "	L = 37 18.5, W = 22.5", D = 23" $\frac{18.5}{12} \times \frac{22.5}{12} \times \frac{23}{12} = 132.97 / 27 = 4.92$ cu yd 50% only est. Per bridge inspection report → 4.92 cu yd @ 2 beam spacings = 9.85 cu yd
Method of Repair (change in design, materials, size, capacity etc.)			Cause of Damage " "
h-kind.			FA <input type="checkbox"/> Quantity 9.85 4.92 ✓ CTR <input checked="" type="checkbox"/> Units cu yd Both <input type="checkbox"/> % Complete 0
Site #	Damage Component Material/Model/Type/Capacity	Location Address/GPS/begin-end	Damage Dimensions: (L x W x D/L x Dia) Electrical/Mechanical/etc.
Abt. #001	Void/Separation between Backwall & Cap	" "	L = 8.25', W = 2'-8", H = 4" $8.25 \times \frac{32}{12} \times \frac{4}{12} = 7.33$ cu ft
Method of Repair (change in design, materials, size, capacity etc.)			Cause of Damage " "
See sketch provided by the Applicant and uploaded to GM: " Drawings-MilkeMilton2-10-25."			FA <input type="checkbox"/> Quantity 7.33 ✓ CTR <input checked="" type="checkbox"/> Units cu ft Both <input type="checkbox"/> % Complete 0
Component Types: 1-Park Equipment 2-Park Building 3-Playground Equipment 4-Fencing 5-Parking Lot 6-Lighting 7-Bleachers 8-Bench 9-Signage 10-Pavilion 11-Table 12-Athletic Field 13-Trash Can 14-Water Fountain 15-Dock 16-Pier 17-Pool 18-Deck 19-Boat Ramp 20-Furniture 21-Athletic Equipment 22-Statue 23-Headstone 24-Grave Marker 25-Mausoleum 26-Driveway 27-Covered Shelter 28-Other (Specify)			Cause of Damage: ① Surface water flooding 2-Wind Driven Rain 3-Sewer Back up 4-Foundation Seepage 5-Lightning 6-High Winds ⑦ Rising Water or Storm Surge 8-Wind Blown Debris 9-Earthquake 10- Fire 11-Earthquake 12- Electrical Power Surge 13- Snow or Ice 14- Other

Applicant Representative Initials: JAH

Recipient Authorized Representative Initials (if applicable): _____

Work Order # (if applicable): 110414 Damage # 1509601

Facility Component Damages

Site #	Damage Component Material/Model/Type/Capacity	Location Address/GPS/begin-end	Damage Dimensions: (L x W x D/L x Dia) Electrical/Mechanical/etc.
Abt #001	Void / Separation between cap and ground	35.925333, -81.519917	$L = 10' - 2"$, $W = \frac{1'}{2}$, $H = 8"$ $\frac{122}{12} \times \frac{1'}{2} \times \frac{8}{12} = 6.78$ cu ft <i>13.56</i>
Method of Repair (change in design, materials, size, capacity etc.)			Cause of Damage
See drawings provided by the Applicant and uploaded to the GM: Drawings - Mike Milton 2-10-25.			①, ②, High Velocity Surface Run off
			FA <input type="checkbox"/> Quantity <i>6.78 13.56</i>
			CTR <input checked="" type="checkbox"/> Units <i>cu ft</i>
			Both <input type="checkbox"/> % Complete <i>0</i>
Site #	Damage Component Material/Model/Type/Capacity	Location Address/GPS/begin-end	Damage Dimensions: (L x W x D/L x Dia) Electrical/Mechanical/etc.
Abt #001	Abutment settlement (Backwall & cap)	" "	$D = 6"$ max. longitudinal $D = 3"$ max. transversal
Method of Repair (change in design, materials, size, capacity etc.)			Cause of Damage
			" "
			FA <input type="checkbox"/> Quantity <i>1</i>
			CTR <input checked="" type="checkbox"/> Units <i>EA</i>
			Both <input type="checkbox"/> % Complete <i>0</i>
Site #	Damage Component Material/Model/Type/Capacity	Location Address/GPS/begin-end	Damage Dimensions: (L x W x D/L x Dia) Electrical/Mechanical/etc.
Method of Repair (change in design, materials, size, capacity etc.)			Cause of Damage
			FA <input type="checkbox"/> Quantity
			CTR <input type="checkbox"/> Units
			Both <input type="checkbox"/> % Complete
Site #	Damage Component Material/Model/Type/Capacity	Location Address/GPS/begin-end	Damage Dimensions: (L x W x D/L x Dia) Electrical/Mechanical/etc.
Method of Repair (change in design, materials, size, capacity etc.)			Cause of Damage
			FA <input type="checkbox"/> Quantity
			CTR <input type="checkbox"/> Units
			Both <input type="checkbox"/> % Complete
Component Types: 1-Park Equipment 2-Park Building 3-Playground Equipment 4-Fencing 5-Parking Lot 6-Lighting 7-Bleachers 8-Bench 9-Signage 10-Pavilion 11-Table 12-Athletic Field 13-Trash Can 14-Water Fountain 15-Dock 16-Pier 17-Pool 18-Deck 19-Boat Ramp 20-Furniture 21-Athletic Equipment 22-Statue 23-Headstone 24-Grave Marker 25-Mausoleum 26-Driveway 27-Covered Shelter 28-Other (Specify)			Cause of Damage: 1- Surface water flooding 2-Wind Driven Rain 3-Sewer Back up 4-Foundation Seepage 5-Lightning 6-High Winds 7- Rising Water or Storm Surge 8-Wind Blown Debris 9-Earthquake 10- Fire 11-Earthquake 12- Electrical Power Surge 13- Snow or Ice 14- Other

Applicant Representative Initials: JIAH

Recipient Authorized Representative Initials (if applicable): _____

Work Order # (if applicable): 110414 Damage # 1508601

SKETCH: (Click grid to upload an image):



Looking SW along Pennell St NE.

NOTES:

Applicant Representative Initials: JAA

Recipient Authorized Representative Initials (if applicable): _____

For FEMA Use Only

Work Order # (if applicable): 110414 Damage # 1508601

101
Category G

SKETCH: (Click grid to upload an image):



NOTES:

Applicant Representative Initials: JAW

Page 5 of 37

Recipient Authorized Representative Initials (if applicable): _____

Work Order # (if applicable): 110414 Damage # 1508601

SKETCH: (Click grid to upload an image):

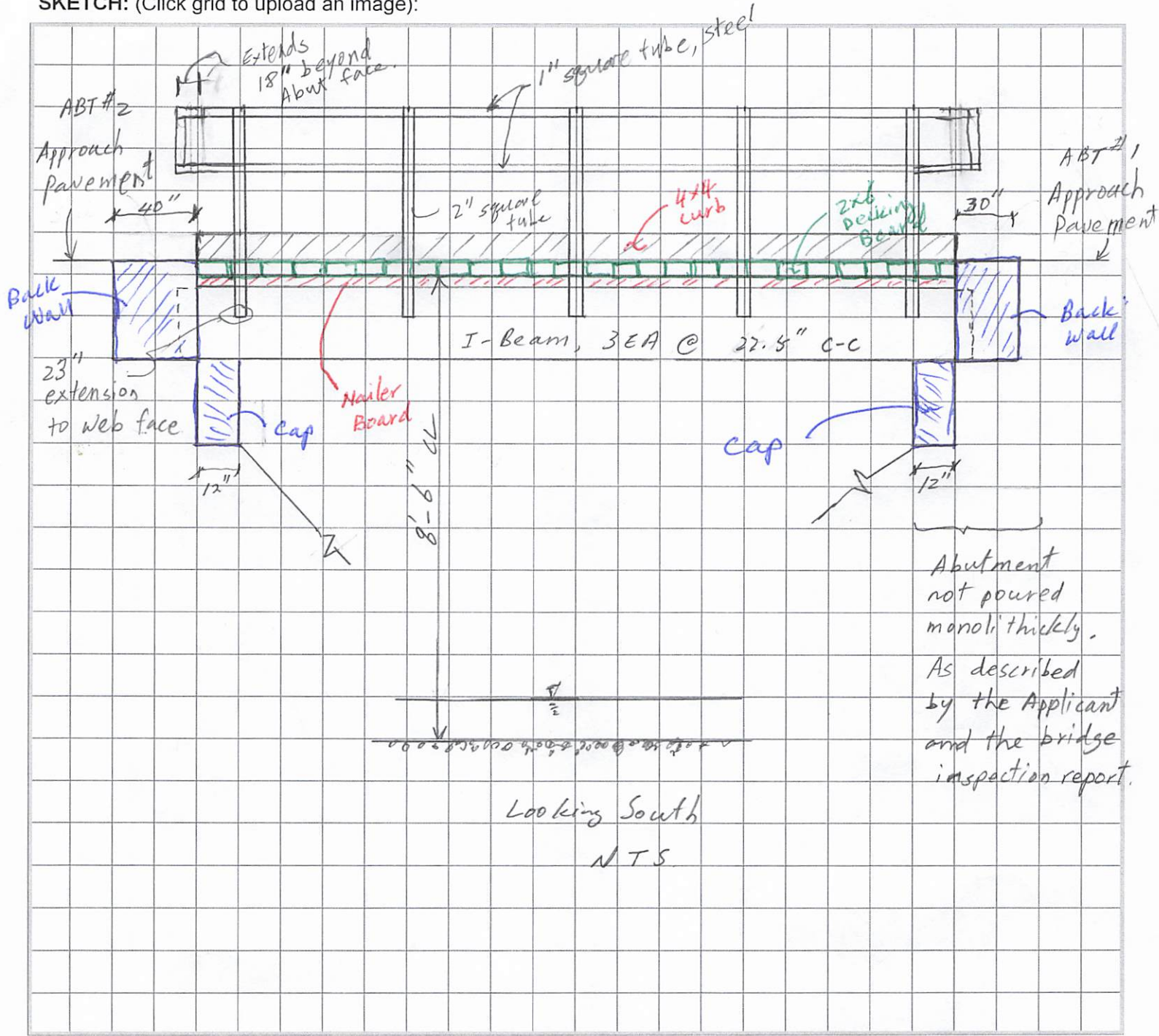

NOTES:

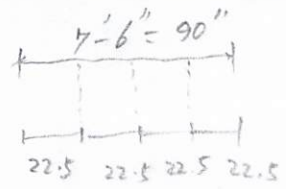

Applicant Representative Initials: JAA

Recipient Authorized Representative Initials (if applicable): _____

SKETCH: (Click grid to upload an image):

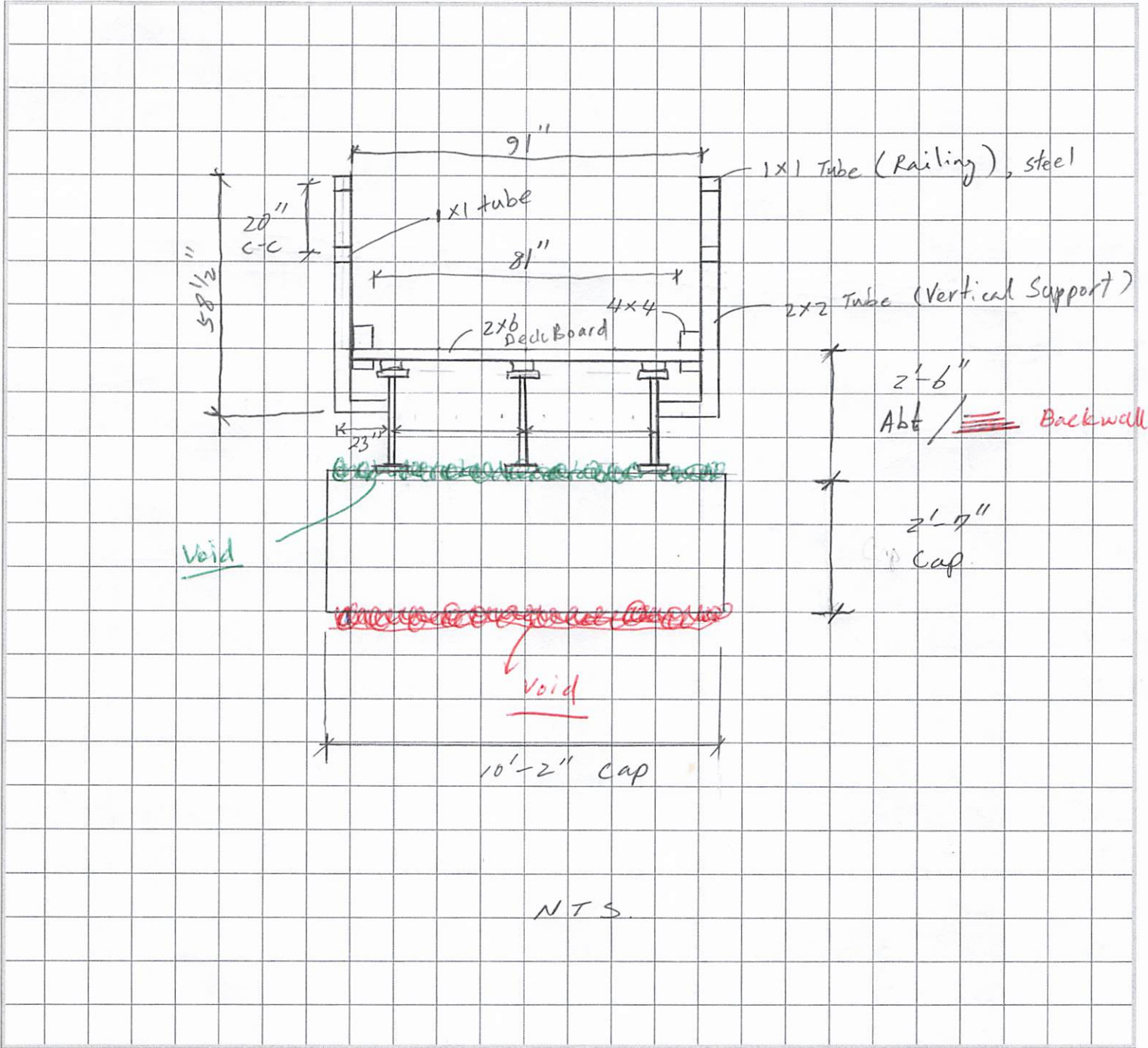

NOTES:

Applicant Representative Initials: JAV

Recipient Authorized Representative Initials (if applicable): _____

NO # 110414
DI # 1508601

BRIDGE INSPECTION REPORT

ABUTMENT SKETCH 1 AND 2



BACKWALL IS MADE AS APPROACH SLAB 8'-2" LONG X 3'-0" WIDE X 2'-6" HIGH
CAP 10'-2" LONG X 12" WIDE X 2'-7" HIGH

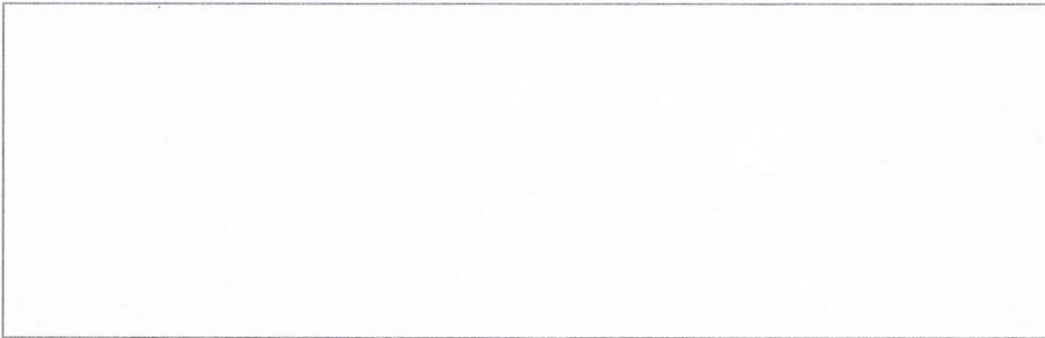

BACKWALL IS MADE AS APPROACH SLAB 8'-2" LONG X 3' WIDE X 2'-6" HIGH
CAP 10'-2" LONG X 12" WIDE X 2'-7" HIGH

Measured in the field:
40" for Abt #2
& 30" for Abt #1

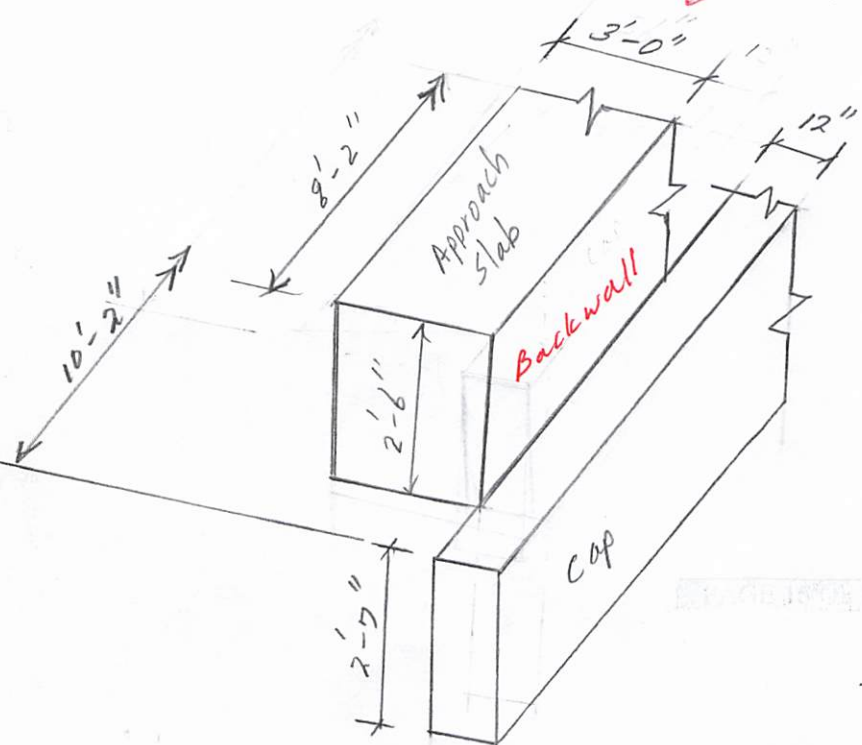

DM

WD # 110414
DI # 1508601

BRIDGE INSPECTION REPORT

BRIDGE LENGTH	35'-4"
OUT TO OUT	7'-6"
BETWEEN RAILS	6'-10"
TIMBER DECK	2" X 6"
BEARINGS	ENCASED IN CONCRETE NOT VISIBLE

BEAMS

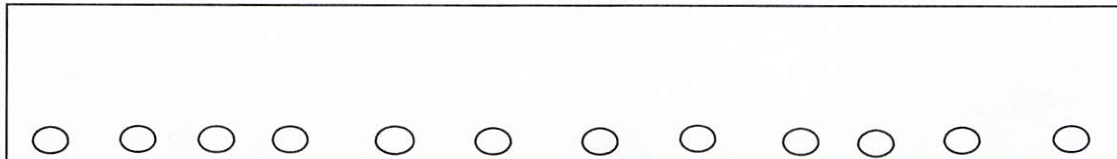
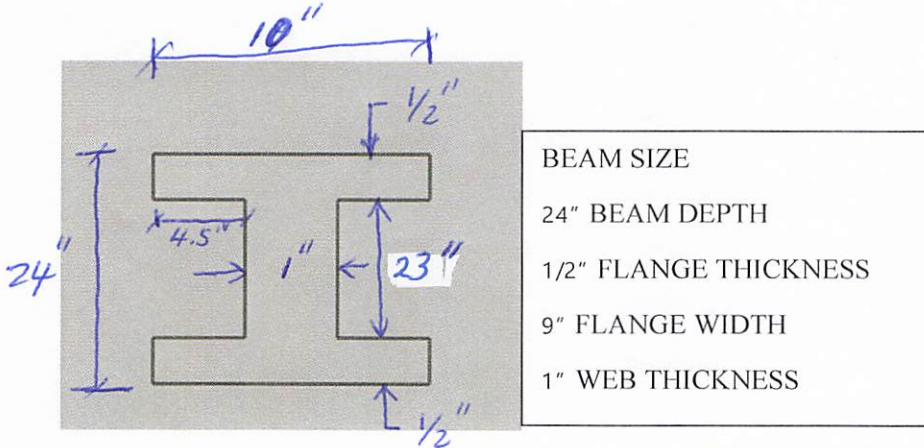

7/8" diameter Holes in Beams Starting at 2'-4" From Abutment 1, 2'-2" Spacing

NOTE FOR SITE INSPECTOR: Please ask the Applicant representative the following questions. Although the PDMG may have already asked some of these questions, the Applicant representative at the site inspection may have additional information. Use the Additional Notes section to record any additional explanation.

Mitigation Considerations

FEMA Public Assistance encourages protection of disaster-damaged facilities by providing assistance for cost-effective hazard mitigation measures that reduce or eliminate the risk of similar damage from happening again in a future event. For each question, elaborate on the answer in the space provided for comments.

<p>1. Identify the specific cause of damage.</p> <p><i>Tropical storm Helene generated a high velocity surface runoff and strong wind that resulted in erosion, debris deposits, and knocked down trees.</i></p>	<p>2. Does the Applicant plan to perform additional work to protect damaged facilities against similar damage in a future event? Explain.</p> <p><input checked="" type="checkbox"/> Yes <input type="checkbox"/> No <input type="checkbox"/> Unsure</p> <p>Comments:</p>
<p>3. Will the Applicant provide a proposal for hazard mitigation work?</p> <p><input checked="" type="checkbox"/> Yes <input type="checkbox"/> No <input type="checkbox"/> Unsure</p> <p>Comments:</p>	<p>4. Would the Applicant like FEMA to prepare a proposal for hazard mitigation work?</p> <p><input checked="" type="checkbox"/> Yes <input type="checkbox"/> No <input type="checkbox"/> Unsure</p> <p>Comments:</p>

Insurance Considerations

FEMA is legally prohibited from duplicating benefits from other sources and will reduce eligible costs by the amount of insurance proceeds received.

<p>1. Does the damaged facility have insurance coverage and/or is it an insurable risk (e.g., buildings, equipment, vehicles)?</p> <p><input type="checkbox"/> Yes <input checked="" type="checkbox"/> No <input type="checkbox"/> Unsure</p> <p>Comments:</p>
--

Environmental & Historic Preservation Considerations

FEMA is required to ensure that work complies with applicable environmental and historic preservations laws, regulations, and executive orders.

<p>1. Is the damaged facility(ies) located within a floodplain or a coastal high hazard area and/or does it have an impact on a floodplain or wetland? Can the project site be impacted by flooding? Will work occur within 200 feet of a waterway/waterbody?</p> <p><input type="checkbox"/> Yes <input type="checkbox"/> No <input type="checkbox"/> Unsure</p> <p>Comments:</p> <p><i>(a) Yes (b) Yes (c) Yes</i></p> <p><i>Bridge crosses Zalk Fork Creek.</i></p>	<p>2. Is the damaged facility located within or adjacent to a Coastal Barrier Resource System Unit or an Otherwise Protected Area?</p> <p><input type="checkbox"/> Yes <input checked="" type="checkbox"/> No <input type="checkbox"/> Unsure</p> <p>Comments:</p>
--	--

Work Order # (if applicable): 110414 Damage # 1508601

Category G

3. Will the proposed facility repairs/reconstruction change the pre-disaster conditions (e.g., footprint – including depth of footprint, material, location, capacity, use or function), including construction of an access road, establishing a staging area, or other work outside of the constructed right-of-way? If yes, describe changes or work outside of the constructed right-of-way. Provide detailed justification for the change (e.g. codes and standards).

- Yes
- No
- Unsure

Comments:

Potential mitigation measures could change both material type and footprint size.

4. Is the damaged facility(ies) listed on a local/state/national historic register or is it a locally recognized landmark? Is it older than 45 years? (Provide the age of the facility) Are there more, similar buildings near the site?

- Yes
- No
- Unsure

Comments:

5. Are there any large, undeveloped or undisturbed areas on, or near, the project site? (Select "yes" if there are large tracts of forestland, grassland, or naturally preserved areas, etc.)

- Yes
- No
- Unsure

Comments:

Both public open & wooded areas and privately owned agricultural land.

6. Are there any hazardous materials at or adjacent to the damaged facility?

- Yes
- No
- Unsure

Comments:

7. Are there any other environmental or controversial issues associated with the damaged facility and/or work item? (select yes if facility is a road maintained by a Tribal Government or if the project necessitates the establishment of a new borrow area or the horizontal expansion of an existing borrow area.)

- Yes
- No
- Unsure

Comments:

8. Are there any known endangered species in the work area?

- Yes
- No
- Unsure

Comments:

Additional Notes / Comments:

Applicant Representative Initials: JAA

Recipient Authorized Representative Initials (if applicable): _____

BRIDGE INSPECTION REPORT

INSPECTED BY:	M. E. RENFRO AND L.H. HODGE
DATE OF INSPECTION:	12/18/2024
WEATHER:	COLD, 32 DEGREES
LOCATION:	LENOIR GREENWAY
FEATURE CARRIED:	LENOIR GREENWAY PHASE 1
FEATURE INTERSECTED:	PENNELL ROAD AND LENOIR GREENWAY
LATITUDE:	35.925333
LONGITUDE:	81.519917
BRIDGE DESCRIPTION:	TIMBER DECK, STEEL SUPERSTRUCTURE, CONCRETE SUBSTRUCTURE, PEDESTRIAN BRIDGE

SITE PHOTO:



BRIDGE INSPECTION REPORT

DRIVE ACROSS BRIDGE/ LL RESPONSE:	
CONDITION:	FAIR
NOTES:	

APPROACHES:	
CONDITION:	POOR
BEGIN APP.	SETTLEMENT AND CRACKING
END APP.	FAIR
NOTES:	

} Not being claimed by the Applicant.

END BENT 1:	
CONDITION:	POOR ✓
BACKWALL	VOID/ SETTLEMENT ✓
BRIDGE SEATS	COVERED WITH CONCRETE
WINGWALLS	
FOUNDATION	CONCRETE FOOTER
BEARING AREA	COVERED WITH CONCRETE
NOTES:	

BRIDGE INSPECTION REPORT

END BENT 2:		} <i>ABT # 2 (EAST) Not being claimed by the Applicant</i>
CONDITION:	FAIR	
BACKWALL	FAIR	
BRIDGE SEATS	COVERED WITH CONCRETE	
WINGWALLS		
FOUNDATION	CONCRETE FOOTER	
BEARING AREA	COVERED WITH CONCRETE	
NOTES:		

DECKING:		} <i>Not being claimed.</i>
CONDITION:	TIMBER, FAIR, SCATTERED DECA Y	
SLAB		
CURB		
WEARING SURFACE		
SIDEWALK		
DRAINS		
NOTES:		

BRIDGE INSPECTION REPORT

RAILING:	
CONDITION:	FAIR-
PARAPET	← 4x4 wooden curb
METAL RAILING	FAIR, SCATTERED PAINT PEELING WITH SURFACE RUST
END POSTS	FAIR, SCATTERED PAINT PEELING WITH SURFACE RUST
GUARDRAIL ANCHORAGE	FAIR, SCATTERED PAINT PEELING WITH SURFACE RUST
NOTES:	

Not being claimed by the Applicant.

SUPERSTRUCTURE:	
CONDITION:	FAIR
BEAMS/GIRDERS	PAINT PEELING WITH SCATTERED SURFACE RUST ←
DIAPHRAGMS	
STIFFENERS	
NOTES:	

Not being claimed by the Applicant.

BRIDGE INSPECTION REPORT

BEARINGS:	
CONDITION:	COVERED WITH CONCRETE
BEARING ASSEMBLY	<i>No damage visible</i>
ANCHOR BOLTS	
PLATES	
NOTES:	

BRIDGE INSPECTION REPORT

ADDITIONAL COMMENTS:

CONCRETE SUPER AND SUBSTRUCTURE-

SETTLEMENT AND 8" HIGH SEPARATION/ VOID BETWEEN FOOTER AND CAP AT ABUTMENT 1. ✓

BRIDGE OUT OF GRADE, UP TO 3", AT ABUTMENT 1. EROSION/ SCOUR, ABUTMENT 1, 4" HIGH X 2'-8" DEEP ✓

LATERAL BANK EROSION IN FRONT OF ABUTMENT ,1 WITHIN 2'-0" OF ABUTMENT ✓

APPROACH PATHWAYS-

UP TO 6" SETTLEMENT IN WEST APPROACH PATH AND SLAB AT ABUTMENT 1

SETTLEMENT IN EAST APPROACH PATH, UP TO ½" DEEP

} only the bridge structure settlement being claimed by the Applicant.

RAILING -

PAINT PEELING SURFACE RUST TO BOTTOM AND TOP FLANGE AND WEB

SCATTERED PAINT PEELING WITH SURFACE RUST TO POST BLOCK SUPPORTS AND RAILS

BEAMS -

7/8" DIAMETER HOLES IN ALL BEAMS

DEBRIS BETWEEN ALL BEAMS ✓

NAILER-

← Not being claimed by the Applicant.

DEACY IN NAILER 1, 1'-8" LONG X 2" HIGH X 1" DEEP 10'-0" FROM ABUTMENT 2

BRIDGE INSPECTION REPORT

church



LOOKING EAST

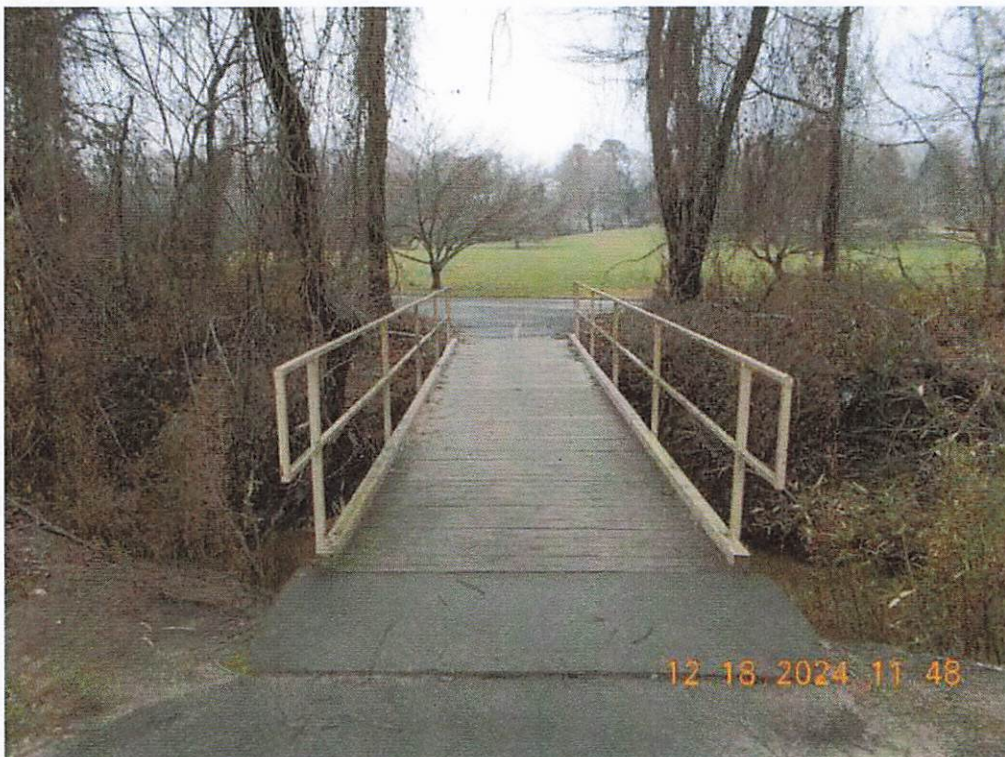

LOOKING WEST

BRIDGE INSPECTION REPORT



UPSTREAM



DOWNSTREAM

BRIDGE INSPECTION REPORT



UPSTREAM *Zacks Fork Creek*



DOWNSTREAM

BRIDGE INSPECTION REPORT



RIGHT RAIL



LEFT RAIL

BRIDGE INSPECTION REPORT



BRIDGE RAILING SUPPORTS



UNDERSIDE OF DECK

BRIDGE INSPECTION REPORT



ABUTMENT 2

BRIDGE INSPECTION REPORT

ABUTMENT SKETCH 1 AND 2



BACKWALL IS MADE AS APPROACH SLAB 8'-2" LONG X 3'-0" WIDE X 2'-6" HIGH
CAP 10'-2" LONG X 12" WIDE X 2'-7" HIGH



BACKWALL IS MADE AS APPROACH SLAB 8'-2" LONG X 3' WIDE X 2'-6" HIGH
CAP 10'-2" LONG X 12" WIDE X 2'-7" HIGH

BRIDGE INSPECTION REPORT

BRIDGE LENGTH	35' -4"
OUT TO OUT	7' -6"
BETWEEN RAILS	6' -10"
TIMBER DECK	2" X 6"
BEARINGS	ENCASED IN CONCRETE NOT VISIBLE

BEAMS

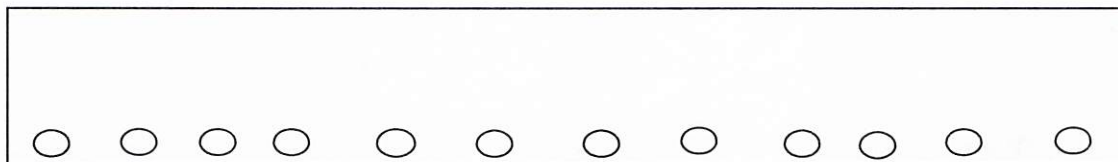
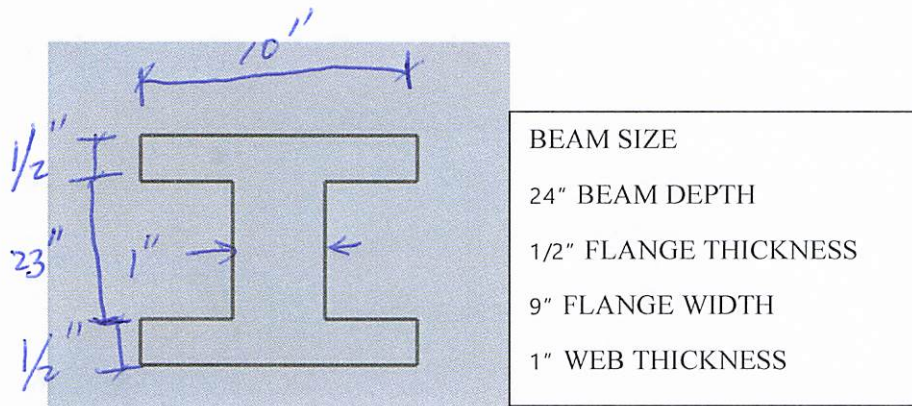

7/8" diameter Holes in Beams Starting at 2'-4" From Abutment 1, 2'-2" Spacing

BRIDGE INSPECTION REPORT

MAINTENANCE REQUEST

- ✓ 1. REPAIR EROSION, VOID/SEPARATION BETWEEN FOOTER AND CAP, AND LATERAL BANK EROSION AT ABUTMENTN 1
- ✓ 2. REMOVE DEBRIS BETWEEN BEAMS
- 3. REPAIR SETTLEMENT IN BOTH APPROACHES (PATHWAY) ← Abut #1, only

Maintenance items, not related to the event per Applicant.

- ~~4. CLEAN AND PAINT BEAMS~~
- ~~5. CLEAN AND PAINT RAILING~~
- ~~6. REPLACE DECAYED AREAS OF NAILER BOARDS~~

1) Erosion

a) Side Slope
Abt #1
(WEST)

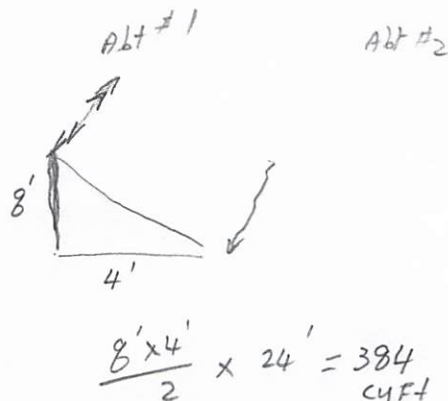
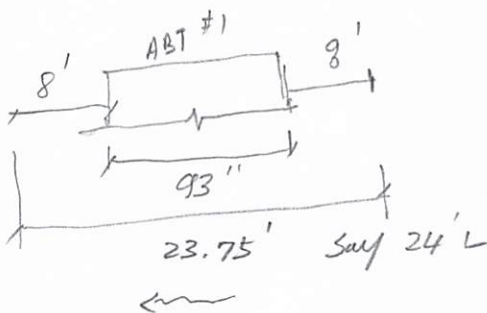

b) Side Slope
Abt #2
(EAST)



$2.2' D \times 9' W \times 24' L = 432 \text{ cu ft}$

2) Debris between beams

Spacing between webs = 22.5" c-c

$22.5'' \times 23'' \times 37' \Rightarrow$

$1.875' \times 1.917' \times 37' = 132.97 \text{ cu ft}$

$\therefore 132.97 @ 2 \text{ spacings} = 265.94 \text{ cu ft} / 27 = 9.85 \text{ cu yd}$

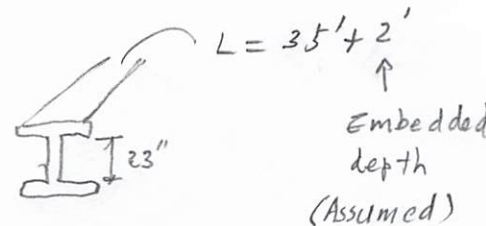

3) Void / separation between ~~chute~~ ^{Backwall} and cap.

L = 8.25' @ 4" high

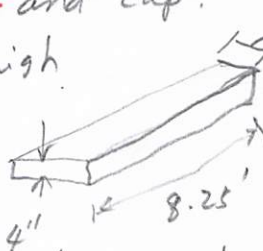

$8.25' \times \frac{4}{12} \times \frac{32}{12} = 7.33 \text{ cu ft}$

4) Void / separation between cap and ground.

L = 10'-2" @ 8" high @ 2' deep

$10.166 \times \frac{8}{12} \times 2 = \frac{13.56}{6} = 2.26 \text{ cu ft}$

BRIDGE INSPECTION REPORT



DEBRIS BETWEEN BEAMS ✓



PAINT PEELING, SURFACE RUST, TOP FLANGE ⇐ Not by the event.

BRIDGE INSPECTION REPORT



EROSION/ SCOUR, ABUTMENT 1 FOOTER, 4" HIGH X 2'-8" DEEP ✓



EROSION/ SCOUR, ABUTMENT 1 FOOTER, 4" HIGH X 2'-8" DEEP ✓

BRIDGE INSPECTION REPORT



VOID/ SEPERATION, 8" HIGH X 2'-0" DEEP X 10'-2" LONG X 2'-8" UP FROM GROUND LINE ✓



VOID/ SEPERATION, 8" HIGH X 2'-0" DEEP X 10'-2" LONG X 2'-8" UP FROM GROUND LINE ✓

BRIDGE INSPECTION REPORT



2" X 2" TUBING WELDED TO BEAMS AT ABUTMENT 1



DECAY IN NAILER 1, 1'-8" LONG X 2" HIGH X 1" DEEP, 10'-0" FROM ABUTMENT 2

← Not by the event

BRIDGE INSPECTION REPORT



SCATTERED PAINT PEELING WITH SURFACE RUST TO WEB OF ALL BEAMS

← Not by the event



SCATTERED PAINT PEELING WITH SURFACE RUST TO POST BLOCK SUPPORTS

← Not by the event

BRIDGE INSPECTION REPORT



SETTLEMENT IN EAST APPROACH, UP TO 1/2" DEEP

✓ Pavement damage not being claimed by the Applicant.
Per the Applicant, no damage to Abut #2 (~~West~~ East Approach)



SCATTERED SURFACE RUST TO RAILS

← Not by the event.

BRIDGE INSPECTION REPORT



UP TO 6" OF SETTLEMENT IN WEST APPROACH AT ABUTMENT 1



*Per the Applicant,
claims
structural
damage
only,
not the
pavement.*



2" WIDE CRACKING IN WEST APPROACH, ABUTMENT 1



*pavement
damage not
claimed.*

BRIDGE INSPECTION REPORT



BRIDGE OUT OF GRADE, UP TO 3" AT ABUTMENT 1 ✓



ABUTMENT 1 EROSION/ SCOUR AND 8" HIGH SEPARATION/ VOID BETWEEN CAP AND FOOTER ✓

BRIDGE INSPECTION REPORT

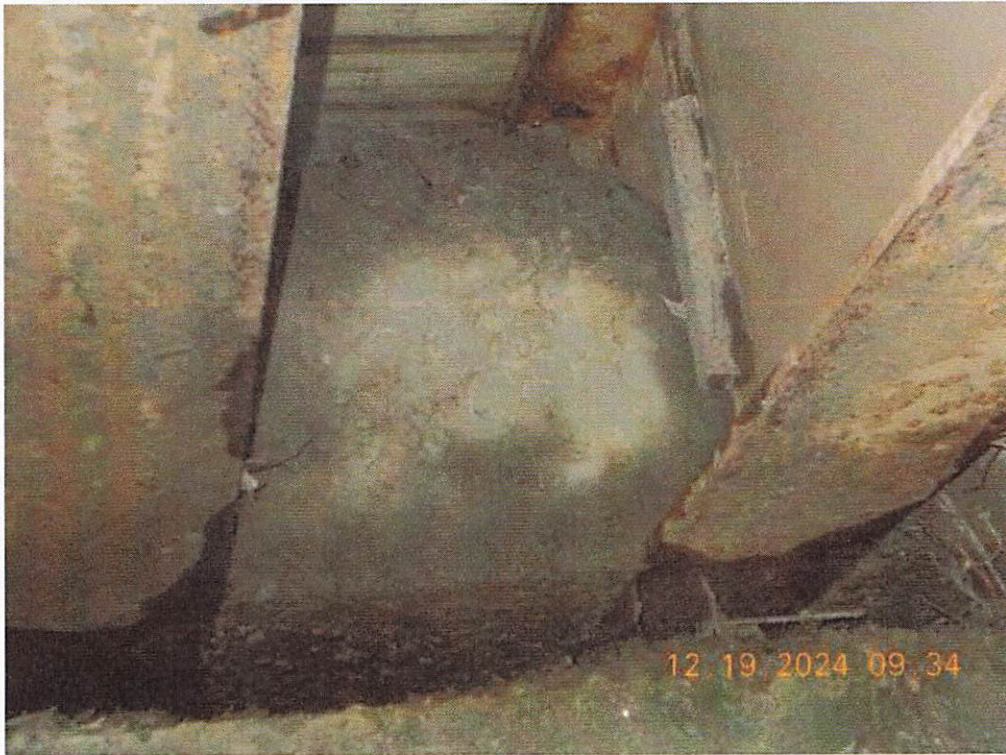

END OF BEAMS AND BEARINGS ENCASED IN CONCRETE



UP TO 6" OF SETTLEMENT IN WEST APPROACH

Board Appointments for Consideration of Approval by City Council

Planning Board

John Arnaud

Term Expires: June 2027

*These appointments were announced at the February 17, 2026 City Council meeting.